



PORT OF HOOD RIVER COMMISSION

AGENDA

Tuesday, October 15, 2024

Port Conference Room

1000 E. Port Marina Drive, Hood River

1. **Call to Order** – 5:00 PM
 - a. Modifications, Additions to Agenda
 - b. Public Comment (5 minutes per person per subject; 30-minute limit)

2. **Consent Agenda**
 - a. Approve Minutes from the September 17, 2024, Regular Session (*P. Rosas, Pg. 3*)
 - b. Approve Res. No. 2024-25-7 Establishing Public Meeting Training Policy (*P. Rosas, Pg. 7*)
 - c. Approve Purchase of Hangar Door with Kevin Cole Const. at the Hoby Hangar (*J. Renard, Pg. 11*)
 - d. Approve Accounts Payable to Beery, Elsner & Hammond, LLP (*D. Smith-Wagar, Pg. 21*)

3. **Informational Reports**
 - a. Height Restriction Memo (*Greenwood, Pg. 25*)

4. **Presentations & Discussion Items**
 - a. North Apron (Jeanette Rd.) Building Criteria (*J. Renard, Pg. 37*)
 - b. Waterfront Development Proposals (*D. Stafford, Pg. 41*)

5. **Executive Director Report** (*K. Greenwood, Pg. 47*)
 - a. Fall Planning Agenda

6. **Commissioner, Committee Reports**

7. **Action Items**
 - a. Approve Resolution No. 2024-25-8 Adopting Updated Employee Handbook (*D. Smith-Wagar, Pg. 89*)
 - b. Authorize Negotiations with Tom Bacci, Kidder Mathews for Real Estate Services
(*K. Greenwood, Pg. 175*)
 - c. Approve 501(c)(3) Bylaws (*D. Smith-Wagar, Pg. 177*)

8. **Commission Call/Upcoming Meetings**
 - a. Upcoming Meetings:
 1. Special Session – October 22, 2024
 - Review and Approve Real Estate MSA with Tom Bacci, Kidder Mathews
 - Review and Approve HRK Change Order
 - Review and Approve SUM Design MSA and Work Order #1
 2. Fall Planning & Regular Session – November 19, 2024
 3. Regular Session – December 17, 2024
 4. Regular Session – January 21, 2024

9. **Confirmation of Commission Directives to Staff**

10. **Executive Session** - An Executive Session will be held in accordance with: ORS 192.660(2)(i) – Performance Evaluations of Public Officers & Employees.

a) Executive Director Performance Evaluation

11. **Possible Action**

12. **Adjourn**

If you have a disability that requires any special materials, services, or assistance, please contact us at 541,386,1645 so we may arrange for appropriate accommodations.

*The chair reserves the opportunity to change the order of the items if unforeseen circumstances arise. The Commission welcomes public comment on issues not on the agenda during the public comment period. With the exception of factual questions, the Commission does not immediately discuss issues raised during public comment. The Commission will either refer concerns raised during public comment to the Executive Director for a response or will request that the issue be placed on a future meeting agenda. People distributing copies of materials as part of their testimony should bring **10 copies**. Written comment on issues of concern may be submitted to the Port Office at any time.*

THESE MINUTES ARE NOT OFFICIAL until approved by the Port Commission at the next regular meeting.

Regular Session

PRESENT: Commissioners: Kristi Chapman, Heather Gehring (arrived at 5:04 p.m.), Mike Fox, Ben Sheppard, and Tor Bieker. **Staff:** Kevin Greenwood, Debbie Smith-Wagar, Daryl Stafford, Ryan Klapprich, Jeff Renard, and Patty Rosas. **Legal Counsel:** Ashleigh Dougill. **Guests:** Amy Schlappi, CAT; Scott Keillor, WSP; Eric Hoffman, Sum Design Studio & Architecture; Gretchen Goss, Goss Creations.

ABSENT: None

1. **CALL TO ORDER:** President Kristi Chapman called the meeting to order at 5:00 p.m.

a. **Modifications, Additions to Agenda:**

1. Move Consent Agenda item 2(b) regarding Parking Permits to Action Item 7(a).

b. **Public Comment:** None

2. **CONSENT AGENDA:**

a. Approve Minutes from the August 20, 2024, Regular Session

~~b. Approve Parking Permits with Mt. Hood Meadows and Columbia Area Transit~~

c. Approve Task Order No. 4 for \$86,500 and Task Order No. 5 for \$96,250 for engineering and design services at the Ken Jernstedt Airfield with PAE

d. Approve Contract with True West Entertainment for Centennial Event Coordination

e. Approve Addendum No. 4 to Lease with Earth & Muscle in Marina East Bldg.

f. Approve Addendum No. 1 to Lease with Aletta Wilson in Marina East Bldg.

g. Approve Property Use & License Agreements with Waterfront Recreation Concessions

Motion: Move to approve Consent Agenda with removal of item 2(b) which will be discussed during Action Items.

Move: Bieker

Second: Sheppard

Discussion: A request was made for staff to include details on how budget-related consent or action items impact the current budget.

Vote: **Ayes:** Chapman, Sheppard, Fox, and Bieker

Absent: Gehring

MOTION CARRIED

3. **INFORMATIONAL REPORTS:**

a. **Bridge Replacement Project Update** – No Discussion

b. **Natural Hazard Mitigation Plan (NHMP) Review** – Commissioner Tor Bieker emphasized the importance of the plan, a 5-year process primarily led at the county level, and highlighted the potential for securing federal and state funding. He clarified that the policy framework is more focused on determining the allocation of funds for capital projects, rather than operational emergency plans.

4. **PRESENTATIONS & DISCUSSION ITEMS:**

a. **CAT/Lot 1 Progress Presentation** – Kevin Greenwood, Executive Director, emphasized the Port's long-standing partnership with Columbia Area Transit (CAT) and acknowledged the recent grant awarded to CAT. He then introduced Amy Schlappi, Executive Director of CAT, for a presentation.

Schlappi provided an overview of CAT's public transportation services, shared updates on ridership statistics, and reviewed revenue sources. She also presented plans for establishing an interregional transit hub at Lot 1, with potential locations being explored, including the possibility of leasing a kiosk from the Port. Parking options for riders were also discussed. The Commission reached a consensus for staff to collaborate with CAT on developing an Intergovernmental Agreement (IGA).

- b. **Architectural Scoping Discussion for Administrative Offices** – Greenwood discussed the Port's efforts over the past year to hire an architect for the relocation of its operational functions due to the bridge replacement project. After a competitive selection process, Eric Hoffman's firm was chosen, but the project was paused due to federal reimbursement rules. In July 2024, the Port received confirmation of a flat dollar amount, allowing the process to continue. Staff now recommends Hoffman's firm develop a study to explore interim or permanent relocation options, reconsidering the old Chamber building at Marina East. Hoffman will present the study in October, with a goal to finalize a contract and begin the 18-month process.

Eric Hoffman from Sum Design Studio & Architecture introduced himself and expressed enthusiasm about the opportunity to collaborate with the Port. He discussed the potential office relocation, suggesting it may be more practical to move to another property within the Port's portfolio. Hoffman then invited the Commission to share their key criteria for the relocation.

Key criteria from the Commission included:

- **Cost Efficiency:** The relocation should prioritize lower-cost areas, avoiding high-value properties like the Marina West/East Building, and explore partnerships with other government agencies to reduce overall costs.
- **Long-Term Sustainability:** The solution should be long-term, avoiding temporary fixes that use public funds inefficiently. The facility should meet future operational needs post-bridge construction, when space requirements are expected to decrease.
- **Optimal Use of Space:** The relocation should make use of less rentable properties, reserving prime locations for future retail or revenue-generating tenants. The potential for a new facility at the airport with rentable spaces was also suggested.
- **Operational Needs:** The facility must accommodate current and future operational requirements, especially for tolling and maintenance. Consideration is being given to splitting tolling and maintenance functions into different locations, reassessing the necessary space and number of staff after the bridge is completed.
- **Future Flexibility:** The location and design should offer flexibility to adapt to changes in operational needs, especially as the Port transitions after the new bridge is built.
- **Additional Funding Opportunities:** The Port should take advantage of potential funding opportunities to support the development of a permanent, multi-functional facility for the Port's operations.

5. **EXECUTIVE DIRECTOR REPORT:** Greenwood provided an update on Rapid Readymix, noting that the lot has been cleared. He also discussed the bridge emergency repair that cost approximately \$1.4 million, which exceeded the budget, and indicated that insurance will likely be involved. Additionally, he highlighted the upcoming Centennial Bridge reception at the Hood River Museum on October 3, featuring a new exhibit of historic photos of the Hood River Bridge.

Greenwood received a call from Merkley’s office regarding an Earmark request for the roundabout project, which was not awarded but may be reconsidered in the upcoming round opening in January or February. A draft agenda for fall planning was included in the packet.

Furthermore, Ryan shared his experience removing large boulders at the maritime lot and presented a 1924 plaque that will be reinstalled on the bridge. A discussion followed regarding lift span training, during which Commissioner Mike Fox suggested implementing simulated training for new lift operators to avoid unnecessary lifting of the span.

6. COMMISSIONER, COMMITTEE REPORTS:

- a. **Centennial Bridge Event** – Commissioner Chapman and Gretchen Goss updated on the centennial celebration scheduled for October 6, noting 2,389 RSVPs as of September 17. The logo design is complete, apparel is ordered, and three musical acts are confirmed. The bridge will close at 9:30 AM, reopen for pedestrians at 10 AM, and vehicular traffic will resume at 12:30 PM. To manage the expected crowd, staff and security will be on-site, with additional support from the sheriff being considered. The event will feature speeches from elected officials and performances, with check-in tables for day-of attendees. The Port is coordinating with local emergency services and has reached out to the sheriff for a marina boat.

7. ACTION ITEMS:

- a. **Approve Parking Permits with Mt. Hood Meadows and Columbia Area Transit.**

Motion: Move to approve parking permits with Mt. Hood Meadows and Columbia Transit.

Move: Sheppard

Second: Gehring

Discussion: Concerns were raised about the lack of compensation for parking on Port property and a suggestion was made for a potential increase in seasonal fees to cover expenses. A discussion followed regarding additional fees, during which it was agreed to honor existing agreements while also developing a more robust policy for the upcoming year.

Vote: **Ayes:** Chapman, Gehring, Sheppard, and Bieker

Nays: Fox

MOTION CARRIED

- b. **Approve Resolution No. 2024-25-4 Establishing Procurement Rules.**

Motion: Move to adopt Resolution No. 2024-25-4 establishing Public Contracting Regulations.

Move: Gehring

Second: Fox

Discussion: None

Vote: **Ayes:** Chapman, Gehring, Sheppard, Fox, and Bieker

MOTION CARRIED

- c. **Approve Resolution No. 2024-25-5 Establishing Business Matters FY 24-25.**

Motion: Move to adopt Resolution No. 2024-25-5 establishing Business Matters.

Move: Bieker

Second: Fox

Discussion: None

Vote: **Ayes:** Chapman, Gehring, Sheppard, Fox, and Bieker

MOTION CARRIED

d. **Approve Resolution No. 2024-25-6 Adopting Donation Policy.**

Motion: Move to approve Resolution No. 2024-25-6 adopting a donation policy.

Move: Bieker

Second: Fox

Discussion: None

Vote: **Ayes:** Chapman, Gehring, Sheppard, Fox, and Bieker

MOTION CARRIED

e. **Approve Procurement for Real Estate Leasing/Sales Personal Services.**

Motion: Move to approve procurement for Real Estate Leasing/Sales Personal Services.

Move: Fox

Second: Gehring

Discussion: None

Vote: **Ayes:** Chapman, Gehring, Sheppard, Fox, and Bieker

MOTION CARRIED

8. **COMMISSION CALL:** None

9. **UPCOMING MEETINGS:** No Discussion

10. **CONFIRMATION OF DIRECTIVES:**

- a. Staff to include details in Commission memos on how budget-related consent or action items impact the current budget.
- b. Review parking agreement policy for the coming year.
- c. Commissioner Chapman requested that staff be given the opportunity to discuss relocation options with the architect.

11. **EXECUTIVE SESSION:** President Kristi Chapman recessed Regular Session at 7:05 p.m. to call the Commission into Executive Session under ORS 192.660(2)(e) – Real Property Transactions to discuss Hood River-White Salmon Bridge Authority (HRWSBA) property needs. ORS 192.660(i) was postponed to a later meeting.

12. **POSSIBLE ACTION:** The Commission was called back into Regular Session at 7:12 p.m. No action was taken as a result of Executive Session.

13. **ADJOURN:** The meeting was adjourned by unanimous consent at 7:12 p.m.

ATTEST:

Kristi Chapman, President

Michael Fox, Secretary

Prepared by: Patty Rosas, Executive Assistant
Date: October 15, 2024
Re: Policy on Public Meetings Law Training



A new training requirement has been established by HB 2805, effective January 1, 2024, mandating that each Board member of the Port complete a training session on public meetings law.

As part of our commitment to transparency and accountability, it is essential that all Board members are well-informed about the regulations governing public meetings. HB 2805 requires that each board member of a governing body with total expenditures of \$1 million or more must complete training on public meetings law, which must be provided or approved by the Oregon Government Ethics Commission.

A resolution adopting this training policy is being presented to the Board for approval. Upon adoption, the policy will be codified into the Port's governance policy according to past administrative practices. Additionally, this policy is necessary to qualify for our 2% Special Districts Insurance Services (SDIS) discount.

RECOMMENDATION: MOTION to approve Resolution No. 2024-25-7 establishing Board member training on Public Meetings Law.

This page intentionally left blank.

PORT OF HOOD RIVER
Resolution No. 2024-25-7

A RESOLUTION ESTABLISHING BOARD MEMBER TRAINING ON PUBLIC MEETINGS LAW

WHEREAS, the State of Oregon has enacted HB 2805, which mandates that each board member of a governing body with total expenditures of \$1 million or more during a fiscal year must complete training on public meetings law; and

WHEREAS, this training must be provided or approved by the Oregon Government Ethics Commission; and

WHEREAS, ensuring that all Board members are well-informed about public meetings law is essential for compliance and effective governance; NOW THEREFORE

THE PORT OF HOOD RIVER BOARD OF COMMISSIONERS RESOLVES AS FOLLOWS:

Section 1. Training Requirement: Each Board member shall attend or complete a training session on public meetings law at least once during their term, effective January 1, 2024.

Section 2. Approval of Training: The training must be provided or approved by the Oregon Government Ethics Commission.

Section 3. Documentation: Board members are required to submit evidence of completed training to the Port's administration for record-keeping.

Section 4. Implementation: Staff is directed to codify this policy into the Governance Policy according to past administrative practices and ensuring all Board members are aware of their training obligations.

ADOPTED by the Board of Commissioners of the Port of Hood River on this 15th day of October 2024.

SIGNED

ATTEST

Kristi Chapman, President

Michael Fox, Secretary

This page intentionally left blank.

Prepared by: Jeff Renard, Airport Manager
Date: October 15, 2024
Re: Replacement of Hangar Door at Hoby Hangar



BACKGROUND:

The Hoby Hangar, which has been in service for several years, is in need of a critical replacement of its main hangar door. Over time, the door has experienced significant wear and tear due to constant usage and exposure to environmental elements. The current door is no longer functioning reliably, posing potential risks to the equipment stored inside as well as to personnel using the facility.

ISSUE:

The existing hangar door has mechanical issues that include:

- Difficulty opening and closing, which impacts daily operations
- Safety Concerns due to malfunctioning components that could lead to an accident.
- The risk of further damage to the structure if the door fails completely.

RECOMMENDATION:

Staff recommends purchasing the custom sliding doors to be manufactured on locally by Kevin Cole Construction, that are more cost-effective compared to the power-up option. Sliding doors offer a practical and reliable alternative without the additional complexities and higher maintenance costs of powered systems.

FISCAL IMPACT:

There was no specific budget allocation for replacing the hangar doors in this fiscal year. However, the capital outlay budget for the Airport is \$286,800, with \$60,000 allocated for AWOS (Automated Weather Observing System) and \$226,800 allocated for the South Apron T-Hangars. If the commissioners agree that this replacement needs to be done, there is currently sufficient budget available to cover the cost. The hangar is currently rented at a discounted rate due to conditions, the new doors will allow us to charge the appropriate rate for the building.

If the AWOS and T-hangars projects require their full budget allocation, a budget adjustment can be made to accommodate this door replacement.

SUGGESTED MOTION:

Motion to approve the purchase of the hangar door for the Hoby hangar in an amount not to exceed \$38,437.92.

ALTERNATIVES:

No alternatives are proposed or recommended.

ATTACHMENTS:

- Quote from Kevin Cole Construction
- Quote from Diamond Doors
- Quote from Schweiss

This page intentionally left blank.

	Kevin Cole Construction						
	OR CCB # 240444						
	3040 Valley View Dr						
	The Dalles OR 97058						
	503-502-8581						
	<h1>Proposal</h1>						
	Submitted on 9/17/2024						
	Invoice for		Payable to				
	Hood River Airport Old SDS Hangar Doors		Kevin Cole Construction				
			Project	Due date			
			Hangar Doors	10/18/2024			
	Description		Qty	Unit price	Total price		
	1) Remove old doors and disposal, install 4 Barn door style doors and track at the top and bottom of the existing opening. Install corrugated metal siding on exterior of doors.		4		\$38,437.92		
	2) \$12,000.00 due within 30 days to secure materials. Remainder of \$26,437.92 due upon completion of project.						
	Materials will be purchased and stored on site until fabrication can be completed. some fabrication will take place off site.						
	***expected completion date 11/29/2024				\$0.00		
	Notes:			Subtotal	\$38,437.92		
					\$38,437.92		

This page intentionally left blank.

Date: July 29, 2024

Quotation



Quote #: **242187 OR**
Rev:



High Quality Custom Engineered Bi-Fold Doors Since 1998

Ph: (866) 325-7600
Fax: (204) 325-0908
400 Airport Dr, Winkler, MB R6W 0J9
DiamondDoors.com

Contact Information:

Company: _____ Phone: _____ Notes: _____
 Name: Jeff Renard _____ Fax: _____ Pictures on the server _____
 Address: _____ Email: Nwjkr7@gmail.com _____
 Hood River, OR _____ Ship To: same _____
 Tag: _____

Door Specifications

	Qty	Clear Opening Size		Actual Door Size		Unit Price	Total
		Width	Height	Frame Width	Bolt Height		
	1	90' - 0"	16' - 0"	90' - 9"	21' - 6"	\$ 59,850.00	\$ 59,850.00

Cladding and Trim Packages (For S Style Door)

Please Specify Color

- Exterior Cladding (28 gauge) & Fastener Package \$ 3,090.00 \$ -
- Exterior Trim Package (includes J Track Cap) \$ 420.00 \$ -

Standard Features Included with Door:

- Single Lever Locking System (Locks both sides of door from one location)
- Prewired Control Box (Up/Down/Stop Push Button Station, Safety & Limit Switches)
(Includes all necessary wiring on door, final power hook-up to panel by others)
- Heavy Duty Electric Opener, Includes Brake Kit, Specify Voltage:
Single Phase: N/A 3 Phase: 208V 460V
- Upper and Lower Weather Seals
- Mounting Hardware for Door Installation (Includes necessary fasteners, etc.)

Specify Locking Handle Side (LO) Left/Outside (RO) Right/Outside	
<input type="checkbox"/> (LO)	<input type="checkbox"/> (RO)

Preferred Delivery Date:

Optional Upgrade Equipment:

- 2" Insulation Package (Incl. EPS board ins. w/ 26ga alum. interior liner & weather seal kit) \$ 5,510.00 \$ -
- 3" Insulation Package (Incl. EPS board ins. w/ 26ga alum. interior liner & weather seal kit) \$ 7,360.00 \$ -
- Foam Weather Seal Kit (Closed cell foam seal placed at door sides and hinge lo) \$ 310.00 \$ 310.00
- AutoLock System Upgrade (Automatically (un)locks door using independent electric motor) \$ 2,380.00 \$ 2,380.00
- Commercial Photoelectric Sensors (Provides momentary push button operation) \$ 280.00 \$ 280.00
- Remotes & Receiver (Includes two 3-button transmitters) \$ 250.00 \$ -
- Column Support Angle Set (Steel angle to reinforce upper portion of wood building column) \$ 0.00 \$ 0.00
- Cable Anchor Kit - 6 x 30' cables w/ connecting hardware to brace endwall \$ 0.00 \$ 0.00
- 36" x 18" Dual Pane PVC Window - Bottom Section \$ 400.00 \$ -
- 16" Bottom Rubber Seal Upgrade \$ 0.00 \$ 0.00
- Steel Header and Supporting Columns \$ 19,700.00 \$ 19,700.00
- \$ - \$ -

Delivery

Approx. Delivery: **14 - 16 weeks**
(From date deposit is received)

- Delivery to Above Address (Based on pooled load) \$ 6,220.00 \$ 6,220.00

- Customer to supply lift equipment for unloading the door.
- Final hook-up to be completed by licensed electrician.
- Unless noted, customer responsible for Install, building header & side columns.
- Deposit required prior to start of production. Balance due prior to delivery.
- All prices are stated in USD. Quotation valid for 30 days.

Sub Total	\$ 88,740.00
	\$ -
	\$ -
Total	\$ 88,740.00

Customer Accepted: _____ Date: _____
Sales Person: _____

C/C #: _____ Exp: _____

Peter Doerksen

25% Deposit:	\$ 22,190.00
Balance:	\$ 66,550.00

GENERIC DOOR LAYOUT

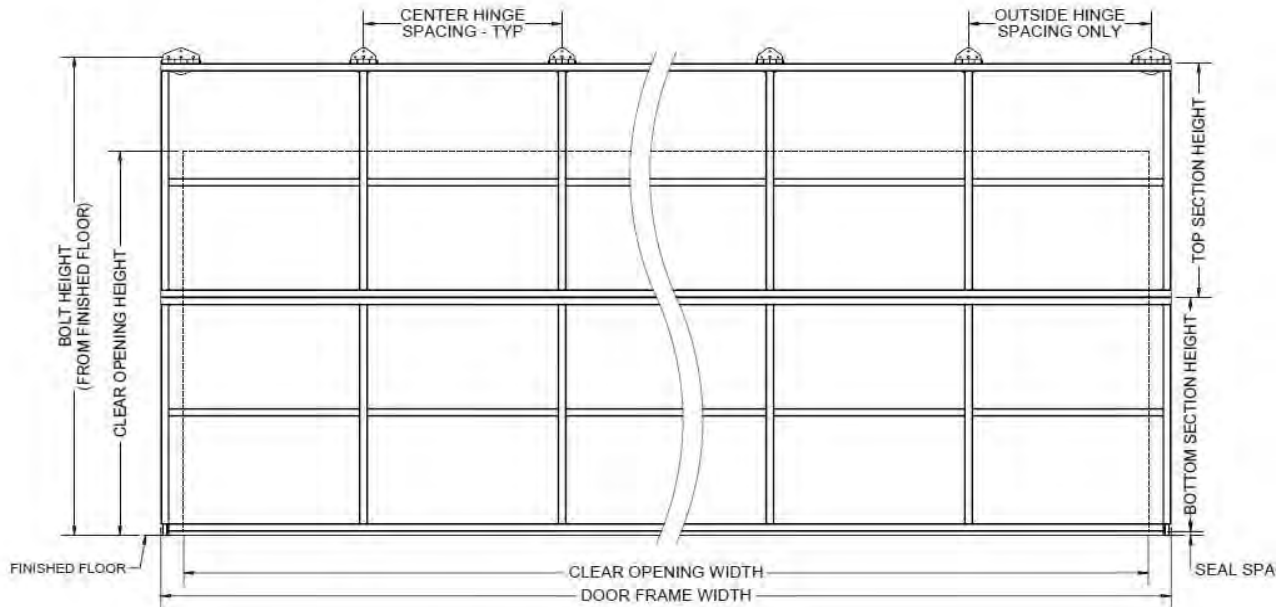

DOOR AS VIEWED FROM EXTERIOR (OUTSIDE)
DOOR LAYOUT SHOWN FOR REFERENCE ONLY
ACTUAL DOOR MAY NOT BE EXACTLY AS SHOWN

Electrical Specifications

Electric Opener..... 7.5 HP
Voltage & Phase..... 208V 3-Phase
Max Breaker.....50A
Min. Wire Size..... 8 AWG
(if < 100' from panel)

Dimensional Specifications

Clear Opening Width..... 90' - 0"	Top / Bottom Section Height.... 126.13"
Clear Opening Height..... 16' - 0"	Seal Space..... 3.56"
Bolt/ hinge Height..... 21' - 6"	Number of Vertical Members... 14
Door Frame Width..... 90' - 9"	(A) Center Hinge Spacing: 83.15"
	(B) Outside Hinge Spacing: 82.65"

Weight & Loading Specifications

Empty Door Weight (frame only)..... 10500 lbs
Door Weight (complete w/28ga cladding) 12000 lbs
Total Shipping Weight 10500 lbs
Avg. Horz. (Outward) Load / Hinge..... 830 lbs
Avg. Vertical Load / Hinge..... 860 lbs
Max Vertical Load / Hinge..... 1070 lbs
Inward Force / Roller..... 5800 lbs

Equivalent Total Outward Load (Pull)
away from building (at bolt height)..... 2920 lbs

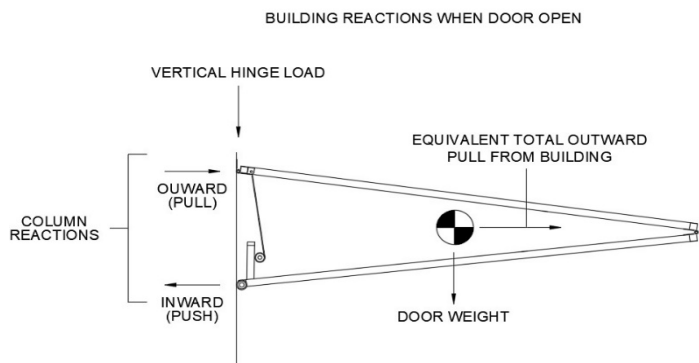

Weight & loading specifications are provided as preliminary estimations only.
Actual door weights/measurments may vary.

Cladding / Trim / Fastener Material Takeoff

Preliminary

"J" TRIM:

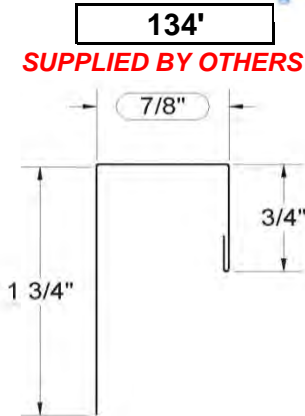

CENTER TRIM:

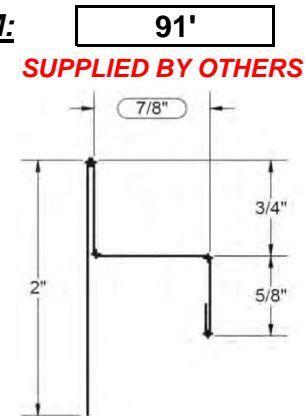

DRIP FLASHING:

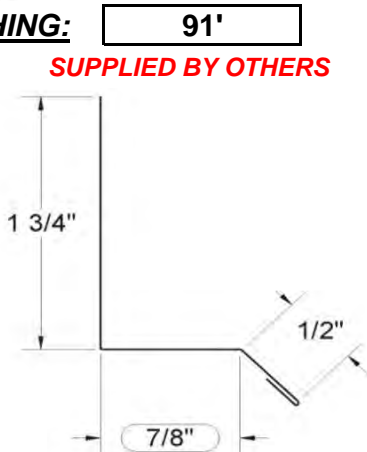

J-TRACK CAP:

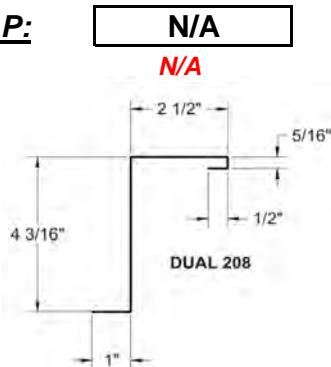

EXTERIOR CLADDING:

	LENGTH
COVERAGE REQUIRED FOR:	90' - 9"
TOP HALF: 31 SHEETS @	126 1/2
BOTTOM HALF: 31 SHEETS @	125

(BASED ON 36" SHEET COVERAGE)

SUPPLIED BY OTHERS

FASTENERS:

3/4" OR 1" TEK SCREWS:	1120
3" TEK SCREWS:	0
4" TEK SCREWS:	0

BASED ON 9" CENTERS, QTY'S INCLUDE 10% EXTRA

SUPPLIED BY OTHERS

NOTES:

CLADDING - 3/4" DOMTEK TUFF-RIB PROFILE (IF) PROVIDED BY DIAMOND DOORS

TRIM PROFILES ARE DRAWN FOR MAX 3/4" CLADDING PROFILE DEPTH. FOR LARGER PROFILES, ADD DIFFERENCE TO THE CIRCLED DIMENSION.

ALL DIMENSIONS AND QUANTITIES REFLECT TOTAL NUMBER OF DOORS ON THE QUOTE / ORDER.

QUANTITIES DO NOT INCLUDE EXTRA WHICH MAY BE REQUIRED FOR WINDOWS, PEDESTRIAN DOORS, OR THE BACKSIDE OF A FREE-STANDING HEADER.

DRAWING NOT TO SCALE, DIMENSIONS IN INCHES.



Ph: (866) 325-7600 Fax: (204) 325-0908
400 Airport Dr, Winkler, MB R6W 0J9
DiamondDoors.com

Attn: Jeff Renard
(1) 90' - 0" x 16' - 0" "S" STYLE DOOR

Reference #	242187 OR
Revision #	
P.O. #	
Date	July 29, 2024



High Quality Custom Engineered Bi-Fold Doors Since 1998

Ph: (204)325-7600 Fax: (204)325-0908 DiamondDoors.com

REQUIRED INFORMATION

Ref #: 242187 OR

REQUIRED TO ORDER

- **Building Details** (enter all)

Building Width	Wall Height	Heel Height	Rafter Pitch
<input type="text"/>	<input type="text"/>	<input type="text"/>	<input type="text"/>

- **Deposit**

Amount	Cr. Card No. & Exp. Date	CVV
\$ 22,190.00	<input type="text"/>	<input type="text"/>

REMAINING BALANCE DUE PRIOR TO DELIVERY

REQUIRED TO SHIP

- **Federal Tax #** **Personal Tax # (SIN)**
 Business Tax # (EIN)
 (Required by US Customs) (check one)

- **Requested Delivery Date**

- **Job Site / Delivery Contacts**

Primary Contact	Cell #
<input type="text"/>	<input type="text"/>
Secondary Contact	Phone #
<input type="text"/>	<input type="text"/>

- **Directions**

* Please contact Russ Suderman for any questions or arrangements regarding shipping

QTY	TYPE OF DOOR	WIDTH ACTUAL CLEAR OPENING	HEIGHT ACTUAL CLEAR OPENING	WEDGE	TOTAL HEIGHT HEIGHT + WEDGE	WIDTH NEEDED DISTANCE YOU WILL NEED BETWEEN YOUR SIDE COLUMNS	HGT. NEEDED DISTANCE YOU WILL NEED UNDER YOUR HEADER	DOOR LIFTING SYSTEM STRAP LIFT OR CABLE LIFT	APPROX. OPENING TIME	ELECTRICAL TYPE	SWITCH LOCATION LI = LEFT SIDE, RI = RIGHT SIDE	DOOR PRICE (EACH)	TRUSS TYPE INTERNAL EXTERNAL	DRIVE TYPE	WEATHER SEAL KIT	SIDE LATCH SYSTEM	TOTALS	
1	BI-FOLD	90' 0.00"	16' 0"	72"	22' 0.00"	90' 0.00"	16' 0.00"	Strap Lift	3000.00	01:55	240-1PH	LI	73036.00	Int.	BD	Strap Auto	450.00	76486.00

BUILDING TYPE	NEW / OLD CONSTRUCTION	BUILDING USAGE	DOOR PLACEMENT	SIDE COLUMN TYPE/SIZE	CUSTOM CUT CORNERS LEFT/RIGHT/BOTH SIDES	External Sheeting Type	External Sheeting Color	<input type="checkbox"/> External Sheeting	NOT INCLUDED
Wood Building	New Construction	Commercial	End Wall	I-Beam		Wainscot Height From Floor	Wainscot Color	<input type="checkbox"/> Wainscot Sheeting	NOT INCLUDED
						Insulation Type		<input type="checkbox"/> Insulation	NOT INCLUDED

BILL TO:
 Company: Hood River Aero
 Street Add:
 City/St./Zip:
 Phone1: 541-399-2464
 Fax:
 Contact: andreas
 Phone2:
 E-Mail: andreas@hoodaero.com

SHIP TO:
 Hood River, OR 97031

NOTES

How Many Days	Cost Per Day	Hotel Per Day	Travel / Ticket
Split - Width One Time		Split - Height One Time	
Tax Exempt	Tax State OR		
Tax Certificate	County Hood River		
	City Hood River		
	District District		

Not Set-Up for Liner Sheeting	<input type="checkbox"/> Liner Flashing	NOT INCLUDED
Liner Sheeting Type	Liner Sheeting Color	<input type="checkbox"/> Liner Sheeting
# Per Door City Total Cost Each	Walkdoor Placement	Walkdoor Type
# Per Door City Total Cost Each	Window Placement	Window Type
	<input type="checkbox"/> Walk Through Door	NOT INCLUDED
	<input type="checkbox"/> Windows	NOT INCLUDED
	<input type="checkbox"/> Free Standing Header	NOT INCLUDED
	<input type="checkbox"/> Top Over Rides	NOT INCLUDED
	<input type="checkbox"/> Side Latch Switches	NOT INCLUDED
	<input type="checkbox"/> Electric Photo Eye Sensors	NOT INCLUDED
	<input type="checkbox"/> Door Base Safety Edge	NOT INCLUDED
	<input type="checkbox"/> Warning Light and Horn	NOT INCLUDED
	<input type="checkbox"/> Emergency Back-Up Hand Crank	NOT INCLUDED
	<input type="checkbox"/> Hyd. - 2 Speed Valve	NOT INCLUDED
	<input type="checkbox"/> Bottom Foam Seal	NOT INCLUDED
	<input type="checkbox"/> 2nd Up/Stop/Down Switch	NOT INCLUDED
	<input type="checkbox"/> Keyed Up/Stop/Down Switch	NOT INCLUDED
	<input type="checkbox"/> Aluminum/Galvanized/Powder Coat	NOT INCLUDED
	<input type="checkbox"/> Hyd. Power Unit Upgrade	NOT INCLUDED
	<input type="checkbox"/> Hyd. Back Up System	NOT INCLUDED
	<input type="checkbox"/> Hyd. Wind Pin(s)	NOT INCLUDED

We are providing PRELIMINARY SPECS primarily for you to pass on to your Building Manufacturer / Engineer / Architect / Contractor for the overall size and hinge locations for this door.

The PRELIMINARY SPECS WEIGHTS and REACTIONS will change, therefore DO NOT design or manufacture the Doors Building Header and the Doors Building Side Columns using the Preliminary Spec Weights and Reactions

TO ORDER YOUR DOOR SIGN AND RETURN THE FOLLOWING

- Schweiss Door Quote - "This Form"
- Send Door Deposit for \$21017.00

AFTER DEPOSIT IS RECEIVED THE FOLLOWING WILL BE SENT TO YOU FOR FINAL APPROVAL

FINAL SPEC WEIGHTS AND REACTIONS will be sent for you to sign and pass on to your Building Manufacturer / Engineer / Architect / Contractor. ONLY use the FINAL SPEC WEIGHTS AND REACTIONS to design and manufacture the Doors Building Header and the Doors Building Side Columns.

- Sign The Final Specs for your Door

<input type="checkbox"/>	Miscellaneous Charges	NOT INCLUDED
<input type="checkbox"/>		NOT INCLUDED
<input type="checkbox"/>		NOT INCLUDED
<input type="checkbox"/>		NOT INCLUDED
<input type="checkbox"/>		NOT INCLUDED
<input type="checkbox"/>		NOT INCLUDED
<input type="checkbox"/>		NOT INCLUDED
<input type="checkbox"/>	Offloading	NOT INCLUDED
<input type="checkbox"/>	Install Supervisor	NOT INCLUDED

<input checked="" type="checkbox"/>	Freight	7580.00
<input type="checkbox"/>	Fuel Surcharge	NOT INCLUDED
<input type="checkbox"/>	Yard Fee	NOT INCLUDED

<input type="checkbox"/>	Sales Tax	NOT INCLUDED
--------------------------	-----------	--------------

- Schweiss doors are provided with temporary electrical wiring that is only to be used for the initial setup.
- Temporary wiring must be removed, hookups must be done by a licensed electrician. Schweiss is not responsible for the final hookup of your door. Failure to do this will void the warranty.
- The customer is responsible for the bi-fold or hydraulic door building header & side columns. Your header, side columns & building must be strong enough to hold your bi-fold or hydraulic door.
- The Contractor or Customer furnishes and installs all door sheeting and trim to cover the door.
- The terms and conditions are included in the attached terms and conditions sheet are incorporated herein.
- I have read through the Purchase Order, the Schweiss Terms and Conditions, reviewed A1, A2, A3, A4, A5, A6 and A7 Spec Sheets and agree to their contents.
- FINAL SPECIFICATIONS will be provided prior to manufacturing that will need to be signed / approved and returned to Schweiss Doors prior to manufacturing.
- Yard Fees may apply if customer is delaying shipping and door has been built according to customers provided timeframe - Rough Date Requested.
- Doors Ordered that do not deliver within a reasonable timeframe (120 Days) may need to be repriced.
- Freight and Fuel Surcharge may need to be adjusted if there is a load coming to your area and you do not take the door(s).
- All doors are priced based on our standard door design. Any revisions will result in additional charges for engineering and production costs.

Brook Schweiss SALES PERSON	GRAND TOTAL OF CONTRACT US FUNDS ONLY PLEASE (Prices Good For 30 Days)	\$ 84,066.00 Plus Applicable Sales Tax
---------------------------------------	--	--

Terms - 25 % Deposit with the order	\$ 21,017.00
Balance Due when door is delivered	\$ 63,049.00
Final Payment By Required - Copy of Cashiers Check Prior to Shipping	Cashiers Check (Only Please)

Customer: _____ SIGNATURE _____ DATE _____ APPROX. DELIVERY DATE REQUESTED _____



SCHWEISS
 72121 470th Street
 Hector, MN 55342
 507-426-8273
 SchweissDoors.com

This page intentionally left blank.



Prepared by: Debbie Smith-Wagar
Date: October 15, 2024
Re: Accounts Payable Requiring Commission Approval

Beery, Elsner & Hammond, LLP	\$10,255.50
---	--------------------

Attorney services per attached summary

TOTAL ACCOUNTS PAYABLE TO APPROVE	\$10,255.50
--	--------------------

This page intentionally left blank.

Beery, Elsner & Hammond, LLP

**1804 NE 45th Ave
Portland, OR 97213-1416
(503) 226-7191
Tax ID #93-1234801**

September 20, 2024

Port of Hood River
1000 E. Port Marina Dr
Hood River, OR 97031
dsmith-wagar@portofhoodriver.com

Our File: PORTHR

SUMMARY OF ACCOUNT

NEW CHARGES PER ATTACHED STATEMENT(S)

<u>Matter</u>	<u>Balance Forward</u>	<u>Payments & Credits</u>	<u>Total New Charges</u>	<u>Balance Due</u>
AIRPORT-Airport	85.50	85.50	2,572.00	2,572.00
GENERAL-General	6,424.50	6,424.50	5,510.00	5,510.00
PERSON-Personnel	0.00	0.00	884.50	884.50
PSAFETY-Public Safety	171.00	171.00	0.00	0.00
PWORKS-Public Works	1,003.00	1,003.00	0.00	0.00
REALPROP-Real Property Transactions	0.00	0.00	1,039.50	1,039.50
RMLIT-Risk Management / Litigation	0.00	0.00	249.50	249.50
TOTAL	7,684.00	7,684.00	10,255.50	10,255.50

LEGAL FEES (per the attached itemization): \$ 10,255.50

DISBURSEMENTS (per the attached itemization): \$ 0.00

Balance (current bill) \$ 10,255.50

Previous Balance Due \$ 7,684.00

Total Payments and Credits \$ 7,684.00

TOTAL BALANCE DUE \$ 10,255.50

This page intentionally left blank.

Prepared by: Kevin Greenwood, Executive Director
Date: October 15, 2024
Re: Height Restriction Enforcement Study



BACKGROUND:

As part of the emergency repair in late June, HDR was contracted to study high level options for early detection and notification of oversized vehicles. The study attached to this memo concludes that deliverable and the emergency contract from the June 27th event.

ISSUE:

Would some type of height restriction indicators be beneficial and worth the investment. The study includes three options:

- Flexible Vertical Clearance Bar
- Dual Beam Overheight Vertical Detection System
- LiDAR Vehicle Detection System

RECOMMENDATION:

Add this discussion to fall planning.

FISCAL IMPACT:

None at this time.

SUGGESTED MOTION:

Not applicable

ALTERNATIVES:

No alternatives are proposed or recommended.

ATTACHMENTS:

Height Restriction Study Memo, Justin Doornink, PE, PhD, HDR Engineering, October 1, 2024

This page intentionally left blank.

Height Restriction Study Memo

Date: Tuesday, October 01, 2024

Project: Task Order 14: Emergency Bridge Repairs to Portal Bracing

To: Kevin Greenwood, Executive Director, Port of Hood River

From: Justin Doornink, PE, PhD, HDR

Subject: Height Restriction Enforcement Frame Study Memo

Background

On June 27, 2024, the Port of Hood River (Port) contacted HDR Engineering, Inc (HDR) regarding bridge members damaged by an overheight vehicle impact on the Hood River-White Salmon River Bridge (ODOT Bridge Number 06645). It was reported that several portal bracing members were damaged after being struck by an oversized vehicle. HDR designed emergency repairs and the bridge was reopened to all vehicular traffic on July 20, 2024. Additionally, HDR was tasked with researching and summarizing solutions for early detection and notification of oversized vehicles, investigating the feasibility of monitoring systems for detection and notification of vehicular and marine impacts to the bridge, and investigating typical practice for signing narrow lane widths on bridges.

Currently, warning signs for reduced vertical clearance are located prior to both the Oregon and Washington bridge approaches. HDR has investigated various alternatives available for oversized vehicle detection and notification. Installing a height restriction system is intended to reduce incidences of bridge strikes caused by oversized vehicles and reduce the frequency of unanticipated repairs to the bridge.



Figure 1: Existing advance clearance warning signs in Oregon side (Left) and Washington Side (Right) (Google Maps)

Alternative 1 – Flexible Vertical Clearance Bar

A flexible vertical clearance bar can be attached from a frame displaying the maximum vertical clearance allowed on the bridge. The clearance bar is assumed to be supported by a steel frame and chains on the Washington approach and by the toll booth structure and chains on the Oregon approach. The elevation of the bar would be set equal to the vertical clearance of the roadway. This alternative is currently used at the Bridge of the Gods and is the lowest cost of those proposed.



Figure 2: Flexible vertical clearance bar at Bridge of the Gods, Washington Approach (Google Maps, 2021)

Pros

- Low-cost alternative
- Simple installation
- Used locally

Cons

- Placement of the system must consider sufficient turnaround of the vehicle.
- Flexible vertical clearance bar may swing and be unreliable in windy conditions
- No notification to Port when a vehicle strikes clearance bar
- Drivers may not notice or ignore the warning.
- The required frame structure may detract from the aesthetic features of the bridge and surrounding area.
- Unable to detect vehicles with overwide dimensions

Alternative 2 – Dual Beam Overheight Vertical Detection System

The dual beam sensor system consists of a transmitter and detection with two infrared or visible red beams installed at the height of the required vertical clearance. It can be augmented with a dynamic message sign, an audible warning system, and real-time system notification. When an overheight vehicle breaks the light beams, a wireless signal activates the warning alerts, notifying the driver and the Port about the intrusion, providing real-time notification so that vehicles can divert into a different route. This warning system has been included as a Specialty Bid Item in the ODOT Traffic Control Plan Design Manual, so there is local precedent for its use.

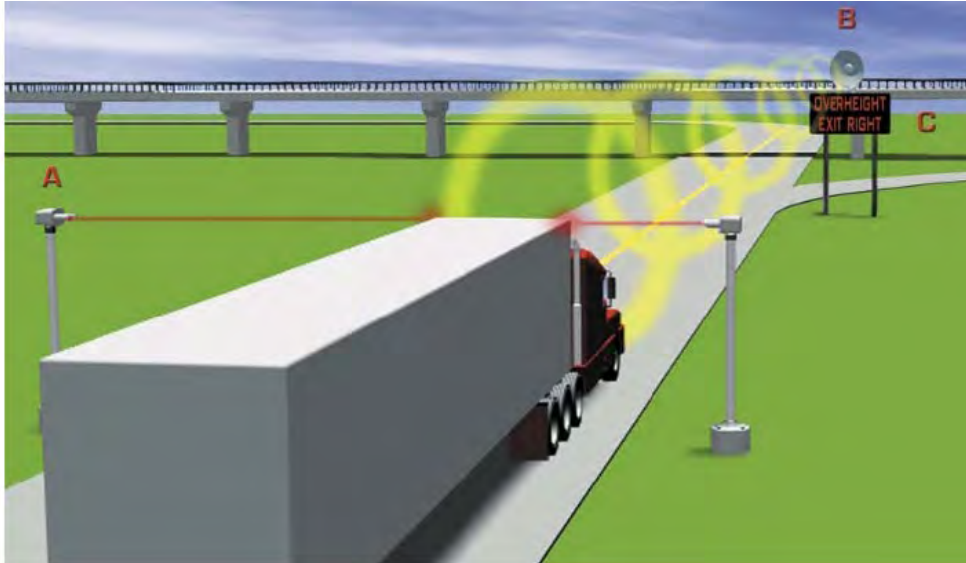

Figure 3: Dual Beam Over Height Vehicle Detection System (Trigg Industries, 2024)

Pros

- Allows for notification to drivers and the Port
- Used locally

Cons

- Placement of the system must consider sufficient turnaround of the vehicle.
- Comparatively high installation cost
- Requires semi-annual or annual maintenance to clean sensor lenses
- Not able to detect vehicle with overwide dimensions
- The overhead detection system may detract from the aesthetic features of the bridge and surrounding area.

Alternative 3 – LiDAR Vehicle Detection System

A LiDAR based vehicle detection system can detect, measure, and classify vehicles in free-flowing traffic conditions. It consists of two or three LiDAR sensors mounted on a steel frame and a traffic controller unit. The sensors scan the upper and side contours of the vehicles and produce point clouds for two-dimensional sections. The traffic controller units use the sensor information to track the relative locations of the 2D profile sections and calculates the vehicle dimensions (length, width, height) with its software.



Figure 4: LiDAR based vehicle detection system for over height and over width vehicles (SICK Free Flow Profiler, 2024)

Pros

- System measures both height and width of vehicles

Cons

- Placement of the system must consider sufficient turnaround of the vehicle
- Highest-cost alternative
- Requires semi-annual or annual maintenance to clean the sensor lenses
- The product vendors do not appear to have existing features for real-time notification to drivers nor the Port when an overheight or overwide vehicle is detected. External programming would be required for systems to provide this enhancement.
- Larger frame required for the system may detract from the aesthetic features of the bridge and surrounding area

Supplemental Measures for Notification of Bridge Impacts

A structural monitoring system at low points along the bridge (i.e., portal members) and at the in-water piers can be used to notify the Port in case of a bridge impact. Accelerometers are placed on bridge members to measure the acceleration and modal frequencies of the structure and facilitate real-time monitoring of the structure. The sensors send the data collected from the member to a cloud platform which provides an alert when data thresholds are exceeded. These thresholds can be calibrated to provide notifications for smaller impacts (i.e., barge rubs) on the

in-water piers. Determining this lower threshold may be difficult considering the piers are subjected to small movements due to vibrations from regular vehicular traffic.

Typical Practice for Signing Narrow Lane Widths on Bridges

The standard warning sign for substandard widths is the “Narrow Bridge” sign. These signs already exist on both the Oregon and Washington Approaches. Guide signs for the bridge also have riders stating the reduced vertical clearance and lane widths. The Narrow Bridge signs are currently close to bridgeheads on each side of the river and could be placed further away to provide more advanced notice.



Figure 5: Existing warning signs for horizontal clearance (Google Maps, 2024)

Conclusion

This study provides a high-level overview of various alternatives for early detection of oversized vehicles to decrease incidences of bridge strikes, as summarized in the matrix below. Proposed locations for the structures on both approaches are depicted in the drawings attached. On the Oregon approach, the frame structure and notification sign would be placed near the toll booth. This location likely does not provide sufficient room for all vehicles to make a U-turn to exit the bridge, but there is assumed to be enough room for traffic to pass the oversized vehicle while it backs up to exit. The Washington Approach is shorter and narrower, so turnaround space is limited, and the proposed location is likely the only workable option. Placement of the system on SR-14 is impractical and not recommended. If the Port wishes to pursue installation of a height restriction system, HDR can further investigate alternatives and develop plans and estimates for

the work. Future phases of this work would include in-depth analysis for vehicle turnaround and confirm proposed locations.

Table 1: Summary of Alternatives for Early Detection and Notification of Oversized Vehicles

Alternative	Real-Time Notification to Drivers	Real-Time Notification to Port	Used Locally	Detection of Overwide Vehicles
<i>1 - Flexible Vertical Clearance Bar</i>	✓		✓	
<i>2 - Dual Beam Overheight Vertical Detection System</i>	✓	✓	✓	
<i>3 - LiDAR Vehicle Detection System</i>				✓

OREGON APPROACH



Port of Hood River

Proposed location for detection frame, all alternatives

Dynamic message/warning sign should be placed minimum 100ft from detection frame.

Example Dynamic Message/Warning Sign



Example Dynamic Message/Warning Sign



Google Earth
Image © 2014-2015

200 ft



This page intentionally left blank.

WASHINGTON APPROACH

Proposed location for detection frame, all alternatives

Dynamic message/warning sign should be placed minimum 100ft from detection frame.

This page intentionally left blank.



Prepared by: Jeff Renard
Date: October 15, 2024
Re: North Apron Building Criteria

The purpose of this discussion item is to gain consensus from the Commission as to setting building criteria for land leases on the North Apron building pad off Jeanette Rd. This discussion is not intended to evaluate the “public” administrative/commercial buildings off Airport Way.

DISCUSSION ITEMS:

1. Parking on the North side of hangars:
 - Who puts it in?
 - Shared cost?
 - Port maintained after installation?
2. The gated road through from Jeanette Rd to Air Museum Rd on airport property satisfies the fire apparatus turnaround need as well as the garbage trucks.
3. The building positions with the doors facing North and South (to avoid the west wind) will cause for the ramp between the buildings to be dedicated to each of the hangars and become part of the square footage leased in the land lease.
4. This design does accommodate the request from Terry B. for the access/easement/thru the fence agreement. In doing so for it to be a taxiway recognized by the FAA it will need to be 115 ft wide.
5. Drive lane will accommodate the vehicular traffic and have the appropriate markings to accommodate the taxiway to the Terry B. property for the few times a year that it is used.
6. The larger building to the south could possibly have doors on both the North and South sides and have bifurcation walls in it making for 4 leasable spaces. (We have to explore what all of the existing extra piping and infrastructure is on the South end.)
7. By putting in a heavy (arborvitae) type barrier we will address the concerns of both of the neighbors to the east by blocking the light and the general visual appearance from thor yards, if we were to put the parking along that side we would need to have it lit.....and?

If there are additional thoughts that I may not have addressed here, please let me know.

RECOMMENDATION: Discussion

FISCAL IMPACTS: As this is a discussion item only there are no fiscal impacts at this time.

ATTACHMENTS: Map of the area and some discussion points.

This page intentionally left blank.

4S2 North Apron Concept

Create a road from Air Museum Rd to Jennette Rd. All hangar parking to be on the north end of development area.

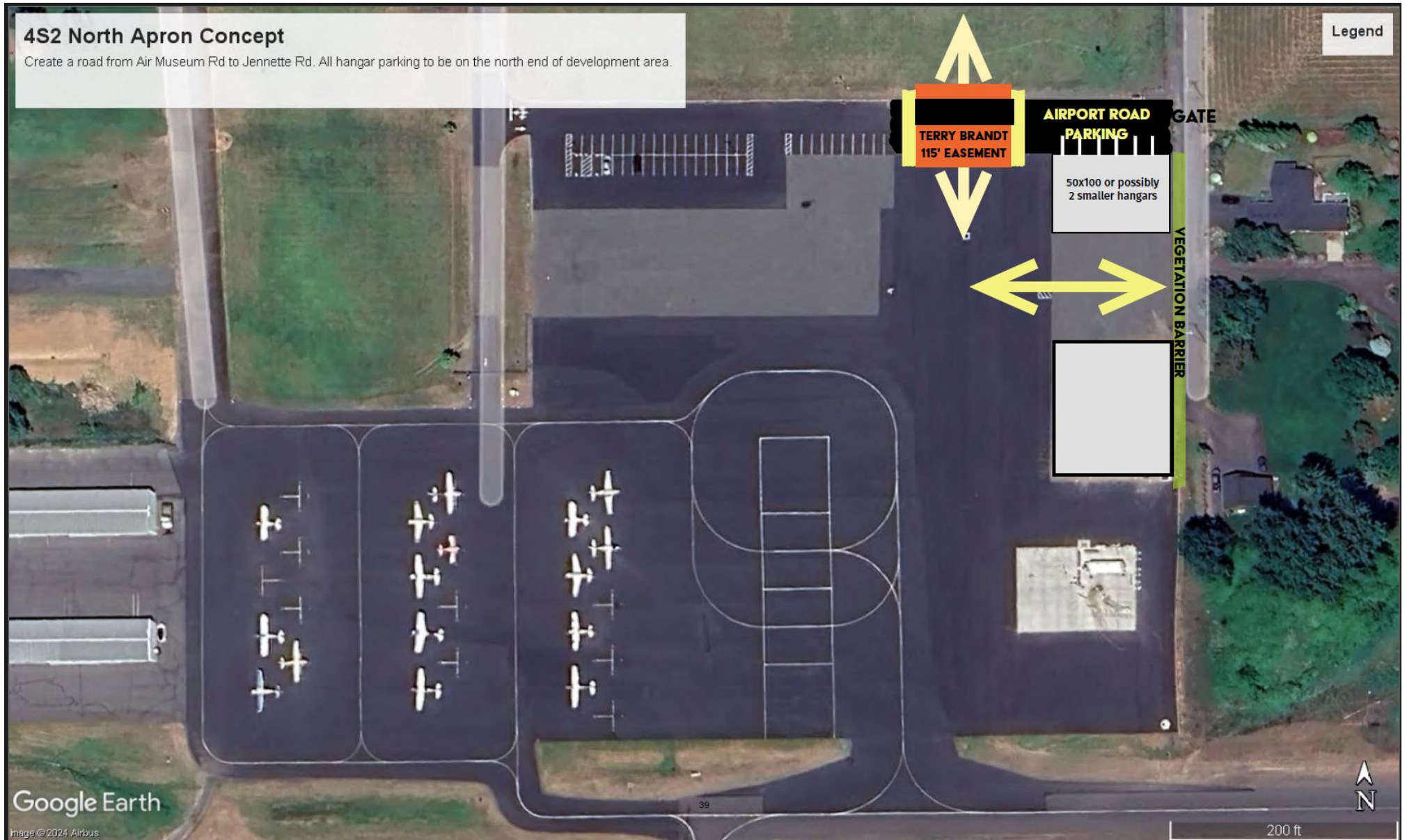

This page intentionally left blank.



Prepared by: Daryl Stafford
Date: October 15, 2024
Re: Waterfront Development Proposals

In April 2024 the Port Commission approved Resolution No. 2023-24-18 Setting Waterfront Recreation Development and Concession Permits that provided direction for staff when receiving inquiries. See Exhibit "A".

The resolution states that the Commission shall review the resolution annually at the Spring Planning Session and adjust if necessary, and that ideas may be presented during public comment for 5 minutes at any regular meeting. ***The resolution also states that presentations will be considered as agenda items twice a year, once in the Spring and once in the Fall.***

In 2024 staff has received inquiries for food carts, floating saunas, jet boat tours, houseboat rentals, and floating barges for recreation. None of these proposals were in line with the current guidelines as described in the Resolution.

Staff would like to check in with the Commission to see if they would like to consider adding any of the aforementioned Recreation Development/Concession proposals to add to the agenda at the upcoming Fall Planning meeting or for the meeting in December.

RECOMMENDATION: Discussion.

This page intentionally left blank.

**PORT OF HOOD RIVER
Resolution No. 2023-24-18**

**A RESOLUTION SETTING WATERFRONT RECREATION DEVELOPMENT
AND CONCESSION PERMITS**

WHEREAS, the Port of Hood River Board of Commissioners regulates the use of Port Property through its Property Ordinance, last adopted via Ord. No. 27 on May 16th, 2023; AND

WHEREAS, the Commission would like to create a policy for recreation concession proposals and recreation business development of the waterfront; NOW, THEREFORE

THE PORT OF HOOD RIVER BOARD OF COMMISSIONERS RESOLVES AS FOLLOWS:

Section 1. Divide Waterfront Recreation into four zones (See Exhibit A).

- A. Zone 1:** Encompasses all Port-owned streets and land surrounding the Marina Basin including the boat ramp, Marina Green, Marina Park, Marina Moorage, Marina Beach, the Marina Jetty, and the East Waterfront Trail.
- B. Zone 2:** Encompasses all Port-owned streets and land surrounding Nichols Basin including Frog Beach, The Spit, Lot #1, the Central Waterfront Trail and Nichols dock.
- C. Zone 3:** Encompasses all Port-owned streets and land associated with the North Central Waterfront including the Event Site, North Central Waterfront Trail along the Jensen Building, and Jensen West parking area.
- D. Zone 4:** Encompasses all Port-owned streets and land surrounding the Hook including the Maritime East Parking, the strip of land to the East of the Water Treatment Plant, and the West Waterfront Trail.

Section 2. Guidelines for all areas.

- A. Presentations:** Public Comment 5-minute waterfront recreation business/concession proposals are allowed at any regular meeting Commission Meeting. Presentations considered for agenda items for a Commission meeting will be allowed twice a year, once in the Spring and once in the Fall.
- B. Food Carts:** No food carts on any Port property until the Port develops a dedicated food cart area with the required infrastructure.
- C. Floating over water buildings/structures:** The Port will not issue any permits for structures/buildings floating over water.
- D. Record of inquiries:** Staff will maintain a list of all waterfront concession inquiries and proposals to present to the commission annually.
- E. Existing Port Waterfront Concessions:** The Port will continue to issue annual permits to existing Concessions that have met the terms of the previous year's permit. The Port reserves the right not to renew a permit for non-compliance or the Commissions desire for different use of the area.

Section 3. Guidelines by Zones

A. Zone #1- East Waterfront Marina Basin and surrounding area:

- a. No new business development or new Concession permits will be issued in or around the Marina Basin until the Port has a better understanding of the needs of the Bridge Replacement Project Contractor.

B. Zone #2- Nichols Basin and surrounding area:

- a. No new business development or new Concession permits issued for the Nichols Basin area until the traffic circle/parking plan has been decided that will help to determine the development of North 1st St. that will provide new access points and upland accommodations.

C. Zone #3- Northcentral waterfront from Jensen west to the east end of the Event Site:

- a. No additional recreation concession rental/school permits available for this area.
- b. No new business development for this area.

D. Zone #4- West waterfront Jensen east lot, The Hook, the area to the west of the Water Treatment Plant:

- a. No Concession permits available for the end of the west end of The Hook.
- b. No Concession permits available for the East Maritime Lot.
- c. Staff should consider proposals for the area previously known as the Dog Park that parallels the Water Treatment Plant on the Southeast perimeter of The Hook.

Section 4. Annual Review. The Commission, through assistance by Port staff, shall annually review and change or adjust resolution at the Port Commission Spring Planning meeting and prior to the subsequent budget’s adoption.

Section 5. Effective Date. The effective date of this resolution is May 1, 2024.

Section 6. Repealer. All previous directives and/or policy resolutions regarding waterfront recreation concession/development permits are hereby repealed.

Adopted by the Board of Commissioners of the Port of Hood River this 23th day of April 2024.

SIGNED

DocuSigned by:
Kristi Chapman
00DEADE439F8421...

Kristi Chapman, President

ATTEST

DocuSigned by:
Mike Fox
1D968775DD2542A...

Michael Fox, Secretary

EXHIBIT A



This page intentionally left blank.

ADMINISTRATION – KEVIN GREENWOOD, EXECUTIVE DIRECTOR

ROUNDBOUT AT LOT 1 / SCOTT KEILLOR, WSP

- *Memo included with report (Attachment A)*
- *IGA with Columbia Area Transit (CAT) being drafted*

PUBLIC RELATIONS & COMMUNICATIONS / GRETCHEN GOSS

- *Memo included with report (Attachment B)*
- *Goss' contract ends in November. Staff is recommending renewing the contract for one year and bringing that to the Commission in November.*

PARKING LOT DEVELOPMENT / CARLOS GARRIDO, HRK

- *The site plan application is currently under 90-day review with the City. Garrido has informed the Port that the original scope did not include the site plan application process as well as other non-design processes. As such, we are working on a change order that will complete the construction drawings and bid process. HRK has submitted the change order and the proposal is currently undergoing a gap analysis with an outside firm. The plan is to submit a staff report, gap analysis and the change order contract to the Commission by COB on Wednesday, October 16, for discussion and approval at a special meeting on Tues., Oct. 22nd.*
- *ODOT initially required a "parking management study" to be conducted based upon the site plan application (Attachment C). The Port's traffic engineer, Kevin Chewuk at DKS, has been working a lesser plan that will meet ODOT needs.*

PROPERTY LEASING UPDATE

- *Marina #1: Aletta Wilson's extension was approved last month, but has since been edited to a different structure and signed*
- *Hoby Hangar: Hoodtech's new lease was approved, but changes needed to be made on the maintenance agreement, and we need a market rate from Jeff to finalize it*
- *T-Hangar: Minor adjustments but nothing substantial (requiring state registration and changed info sheet format)*
- *Anne is currently working on 3 leases - Wolf Ceramics (Big 7), The Clay Commons (Big 7), and the Oregon Human Development Corporation (Wasco),*

COAST GUARD RULE CHANGE FOR LIFT REQUESTS

- *Received word from District 13 that the Port's request for a 30-day lift notice was rejected. Steve Fischer, Bridge Mgr., indicated that in addition to concerns from headquarters (apparently there is no 30-day notice period anywhere in the US), they did receive an objection from a boat owner at the Portland Yacht Club. Fischer noted that a letter is forthcoming, and staff will include in next packet as soon as it is made available. The purpose for the increased notice was to ensure that engineers were available to assist with requested lifts due to recent span concerns.*

OTHER ACTIVITIES

- *Please see the draft Fall Planning agenda scheduled for November 19 included in packet (Attachment D). Are there any other items that should be included?*

- *MCEDD is soliciting candidates interested in serving on the ODOT Region 1 Hood River ACT. There are two vacancies currently including a business representative and an at-large position. There are two other publicly-elected positions selected by the City and the County respectively.*
- *Conducted real estate interviews with project coordinator.*
- *MCEDD is hosting the 2024 Columbia Gorge Economic Symposium November 1 from 8am to 1230pm at the For Dalles Readiness Center. Draft agenda included in packet (Attachment E).*
- *Meeting scheduled with Oregon State University, Director of Extension External Relations, on Oct. 16. They are interested in learning more about the Port's involvement with recreation and economic development.*
- *Heritage Council thank-you breakfast scheduled for November 7th. More details forthcoming from Will Ennis.*
- *Intergovernmental Agreement (IGA) between Columbia Area Transit (CAT) and Port received and currently under review.*
- *Goss Communications contract is nearing completion. Staff is recommending a one-year renewal. Gretchen has helped staff with social media posts, newsletter writing and was the lead staff person for the Centennial Committee. An updated one-year contract will be brought forth in November.*
- *Commissioner Fox and I attended the Museum Open House on October 3rd for the opening of the Bridge Centennial Exhibit.*
- *Eric Hoffman, SUM Design, has submitted a rough Scope of Work included in packet (Attachment F). He is currently working on a budget and schedules. Plan is to present to Commission at a Special Commission meeting October 22nd.*
- *SDAO Annual Conference is scheduled for Bend, Ore. on February 6-9, 2025. Please let staff know if you'd like to attend. This is one of the better board conferences of the year.*

ADMINISTRATION – PATTY ROSAS, EXECUTIVE ASSISTANT

- *You should have received an email from Vector Solutions regarding the Public Meetings Law training. The course is approximately 16 minutes long, and **all Board members are required to complete it to qualify for our 2% insurance discount.** Please ensure the training is completed by **October 18, 2024.***
- *The new website is nearing completion, though we've encountered a setback with the live cams. We're actively working on resolving the issue before we go live. In the meantime, please use the temporary link view the new website: <http://portofhoodriver.specialdistrict.org/>*
- *SDAO Annual Conference is scheduled for Bend, Ore. on February 6-9, 2025. Please let staff know if you'd like to attend. This is one of the better board conferences of the year.*

FINANCE – DEBBIE SMITH-WAGAR, FINANCE DIRECTOR

AUDIT

- *The audit has kept Finance busy. We have to generate everything out of the old software since the new software went live on July 1 and the fiscal year being audited ended on June 30. Everyone is happy this is the last audit we have to do out of the old system!*

REPLACEMENT BRIDGE

- *The group responsible for funding and finance are continuing to work on getting the Bridge Authority a method of paying for invoices before they can be reimbursed. We believe Hood River County will be extending a line of credit to the Bridge Authority. Legal counsel is working on the agreement.*

- *The Finance department is providing information and assisting in some toll analysis for the new bridge. An in-depth traffic and revenue study is underway and will take several months to complete.*

INFORMATION TECHNOLOGY

- *The toll booth will have a direct internet connection so it can function without a connection to the administration building. Spectrum was able to run a line into the east side of the booth, and equipment was scheduled to be installed on October 10. As we plan to vacate the existing Port office, the Port of Cascade Locks will also need to be separated from the administration building. Fortunately our back office tolling system, P Square, recently completed a migration to the cloud, so all we need is an internet connection to connect.*
- *The Port is also upgrading firewalls as P Square moves their equipment out of the server room. P Square's equipment was nearing its end of life, so the Port needed to find an alternative. Radcomp is taking the lead on getting the equipment up and running. All equipment being purchased can be moved to a new location when the Port's new home is determined.*

WATERFRONT/MARINA – DARYL STAFFORD, WATERFRONT MANAGER

- *Gorge Jr. Sailing had another successful season providing lessons in the Marina. Please see the attached report they provided (Attachment G).*
- *Over the last year the Port has received concession inquiries for a floating barge, floating saunas, and various food carts. The Port's current policy is that they do not want to grant any concession permits for anything on the water, or food carts, until the Port puts in the needed infrastructure. If the Commission would like to revisit this policy staff will add it to the Fall Planning meeting.*
- *Staff received complaints regarding trash overflowing from American Cruise Line's (ACL's) dumpster on the Marina Beach and are currently working with ACL to get XL dumpsters with lids. Part of the problem is that local folks are bringing their home trash, causing an abundance on the ground leaving mess.*
- *Fisherman have been cleaning fish on the guest, temporary tie up, and fuel docks. This is a violation of Port Marina Rules and Regs. Staff will work with HRSO & Dept of Fish and wildlife for enforcement and propose at a future meeting a penalty to be added to the master fee schedule for violators.*
- *Someone hired a crane owned by Rapid Ready Mix to haul out a boat on the Marina Jetty without Port permission. Port staff has not previously worked with this company for vessel haul outs. They have been contacted and now know that they must have permission and insurance naming the Port as additional insured. The Port does not have a policy for craning however this is something that will be brought to the Commission soon.*

GROUNDS AND FACILITIES – RYAN KLAPPRICH, FACILITIES MANAGER

- *The facilities staff would like to move forward with the engineers recommendation of monthly maintenance lifts. As stated from WJE this will ensure the bridge operation when needed and will help illuminate the corrosion that has been called out in the recent M&E inspection, we are seeing gears that have corrosion starting to form from the lack of use. The continued lifting will also aid in the comfort while operating when needed for navigational traffic, the long periods between operations has staff on edge and nervous. The monthly lifts will also allow for the training of new operators and allow for the needed maintenance (new wire rope lubrication, electrical contact exercises). WJE memo included in packet (Attachment H).*

- *Wasco building improvements for new tenants.*
- *Big 7 mold testing in suite 203.*
- *Scheduled mold tech for recommended remediation steps.*
- *Marina dock repairs.*
- *New hire Tylor Singleton for crew supervisor.*
- *Airport wetland mediation work and 1st year inspection completed.*
- *Water off at all parks and bathrooms.*
- *Summer staff gone.*
- *Centennial celebration set up.*
- *Starting winter prep in buildings and park bathrooms.*
- *Putting together revised 8 year CIP with new inspection report.*
- *Jensen repairs for Tofurky (inspection failures).*
- *Jensen fire system repairs (Glycol added to outside system from earlier damage)*
- *Otis completed elevator inspections.*
- *Verizon completed site visit at Jensen for cell antenna.*
- *Underwater inspection of bridge piers (middle of October).*
- *Moving forward on Big 7 window with Historical Landmark review permitting.*
- *Found contractor for long time needed dock repairs that are outside staff capabilities.*

-###-

Other Attachments:

- *September Airport Report (Attachment I)*
- *September MIS Summary (Attachment J)*
- *September AAC Agenda & Task List (Attachment K)*
- *OAMA Conference Notes (Attachment L)*
- *September FBO Report (Attachment M)*

Memorandum

Date: October 9, 2024

Subject: Lot 1 Progress Report

From: Scott Keillor; Jodi Mescher

To: Kevin Greenwood
Port of Hood River Commissioners

LOT 1 PROGRESS REPORT

Deliverables Completed

Key tasks and deliverables completed through October 2024 included:

- The project team submitted quarterly and annual (from 2023) grant reports for the DAS Coronavirus State Fiscal Recovery Fund Grant and the Economic Adjustment Assistance Program Grant.
- The Port met with Senator Bonham to introduce the project and funding needs.
- The Port amended the WSP and KPFF work scopes to include additional land use and transportation modeling for Lot 1 and the waterfront area in response to ODOT's request to support review of planned trips and design justification for the roundabout (RAB).
- The design team met with ODOT technical staff to discuss RAB design considerations and the ICE.
- The project team worked with the Port to model three land use scenarios at varying intensities of development to inform additional transportation modeling for the waterfront area.
- The project team met to develop a parking lots Gap Analysis memo to support a complete bid process, and the Port provided an NTP under the PM task, with plans for a future general services task to handle emergent needs.
- The design team submitted a cost estimate for the RAB design and construction, first street design and construction, and transit design and construction.
- The design team continued work on a RAB concept design for ODOT review with ICE and identified parameters and preliminary alignments.

Upcoming Deliverables

- Draft Factsheet No 1 and Website content No.1
- Port's new parking lots Gap Analysis memo.
- Land Use Scenarios and Transportation Analysis memo.
- Advance Intersection Control Evaluation (ICE) and 2nd and Riverside Evaluation
- Submit ICE to ODOT based on land use scenarios and transportation analysis for RAB justification.
- Identify basin areas for stormwater analysis and discuss possible solutions with the City of Hood River.

Key Milestones

- Mid-October:
 - WSP to submit quarterly grant reports
 - parking lots Gap Analysis
 - DKS to submit initial trip generation and transportation analysis
- End of October:
 - WSP to submit final Land Use Scenarios and Transportation Analysis memo to Port and KPFF
 - KPFF to complete and submit ICE to ODOT

Budget Summaries

1. WSP Owner’s Representative (O/R) Contract spent is estimated at \$55,741 on non-contingent tasks (10%) through August 2024

Task Number	Task Name	Contract Value	Current Invoice	Previous Billed	Total Billed to Date	Contract Balance	Percent Invoiced
1.0	Project Management	62,759.15	5,748.29	6,612.88	12,361.17	50,397.98	19.70%
2.0	Grant Writing	151,620.71	1,695.88	9,540.02	11,235.90	140,384.81	7.41%
3.0	Grant Management	9,999.19	2,354.46	2,530.34	4,884.80	5,114.39	48.85%
4.0	Due Diligence	8,948.06	0.00	0.00	0.00	8,948.06	0.00%
5.0	Port and Agency Coordination	163,342.64	5,843.82	8,877.73	14,721.55	148,621.09	9.01%
6.0	Communications Materials	10,461.89	193.00	0.00	193.00	10,268.89	1.84%
7.0	YE Documents	5,032.14	0.00	0.00	0.00	5,032.14	0.00%
Expenses	Expenses	2,998.20	0.00	0.00	0.00	2,998.20	0.00%
Sub_Sprout	Sprout	15,000.00	0.00	0.00	0.00	15,000.00	0.00%
Total		430,161.98	15,835.45	27,560.97	43,396.42	386,765.56	10.09%

2. KPFF/DKS/Walker Macy Design Contract: Est. \$142,000 spent of \$487,000 budget (30%) through August 2024.

Risks and Mitigations

1. ODOT may not approve the RAB even after the ICE is submitted. We plan to complete the level of design needed get the ICE approved.
 - a. Mitigation: Submit additional land use scenarios and transportation analysis memo to inform the ICE. Continue to work with ODOT to understand expectations, and work with developers toward letters of intent for Lot 1 and broader waterfront development potential.
2. STIP amendment approval is required, or grant funds may be at risk.
 - a. Mitigation: Long-term need to work with ODOT on project design and warrants.
 - b. Mitigation: Long-term need to work with funding partners on project scope and schedule.

NEXT STEPS

The design team intends to advance the concept design and complete the ICE for ODOT review. The team will continue to coordinate with ODOT to further the ICE and concept design review and approval. The team will also work towards a STIP amendment contingent on ODOT review of the ICE to indicate acceptance of the RAB design concept.

CC: October 2024 Lot 1 tracker/schedule

This page intentionally left blank.

Prepared by: Gretchen Goss

Date: October 9, 2024

Re: Newsletter and Social Media



Newsletter:

The newsletter is currently on a biannual publication, with the last publication happening in July, and the next in December 2024. All articles and materials will be submitted to Pageworks by November 7th.

Articles are being drafted and researched – Centennial Bridge Celebration, Airport happenings, Spotlight on Toll Booth operators, FAQ about the Port. The goal is to get the entire newsletter translated into Spanish for this publication.

Discussions around going mostly digital are in the works – with paper copies located in specific stores or buildings (local libraries, City Hall, etc).

Social Media:

While the Facebook comments tend to be negative, it is creating great ideas on what the Port needs to address in upcoming newsletters – a lot of misinformation that can be address|by writing small articles or creating fun infographics on the issues.

Instagram is beginning to grow, with the latest post having 1.2k likes, 25 comments, and 18,220 views. The Port is working to gain followers by strategically sharing the posts of community partners, showing that we are indeed an active community organization. Stories have overall good viewing, and we are gaining new followers each week.

Social media calendar for Oct, Nov. and December is in the works, with hopes of creating informative reels.

Prepared by: Gretchen Goss

Date: October 9, 2024

Re: Centennial Bridge Celebration



The Centennial Bridge Celebration was held on October 6, 2024, with an estimated 4,000 people in attendance.

While final costs are being calculated, the overall feedback from the community was positive. We heard people saying they “had been waiting for this their whole lives”, and there was dancing and singing on the bridge when a jazz band showed up to join Erick Haynie in song. Mayor Blackburn described the event as “First Friday on steroids”.

The Port did a great job of acting as community partner, asking and encouraging many local organizations to be involved. Senators King and Wyden both arrives to speak, with a representative from Senator Cantwell’s office taking part in the day as well. With two photographers and a drone in the air, the Port will be receiving some great media from the event.





Oregon

Tina Kotek, Governor

Department of Transportation
 Transportation Region 1
 123 NW Flanders St.
 Portland, OR 97209-4012
 (503) 731-8200
 Fax: (503) 731-8259

9/17/24

ODOT # 13424

ODOT Formal Response

Project Name: Anchor Way and Portway Parking Lots	Applicant: Port of Hood River
Jurisdiction: Port of Hood River	Jurisdiction Case #: 2024-24, 2024-23
Site Address: 910 Portway Avenue and 403 Anchor Way	State Highway: I-84 Exit 63 Interchange

The site of this proposed land use action is in the vicinity of the I-84 Exit 63 interchange. ODOT has permitting authority for this facility and an interest in ensuring that this proposed land use is compatible with its safe and efficient operation.

LAND USE PROPOSAL

The Port of Hood River is proposing a 59-space parking lot on Anchor Way and a 76-space parking lot on Portway.

COMMENTS/FINDINGS

Traffic Impacts

The traffic study submitted for the land use application assumes that the addition of approximately 135 parking spaces intends to serve "over flow" parking purposes only. It is unreasonable to assume that the significant increase of parking would not increase trips to the area. A parking management study should be submitted demonstrating the existing trips/parking spaces and the potential increase and its effect.

Contact the ODOT Traffic Contact identified below for scoping the parking management study.

ODOT RECOMMENDED CONDITIONS OF APPROVAL FOR LOCAL JURISDICTION

Traffic Impacts

- The applicant shall prepare a parking management study demonstrating the existing trips/parking spaces and the potential increase and its effect on the transportation system. The study must be provided to ODOT and city engineers for review and approval. The city engineer may require mitigation to address impacts to the transportation system.

Contact the ODOT Development Review Planner identified below for further coordination or questions regarding ODOT comments and requirements during the land use process.

Please send a copy of the Notice of Decision/Staff Report with conditions of approval to:

ODOT_R1_DevRev@odot.oregon.gov

Development Review Planner: Marah Danielson	Marah.b.danielson@odot.oregon.gov
Traffic Contact: Avi Tayar, P.E.	Abraham.Tayar@odot.oregon.gov

This page intentionally left blank.

Port of Hood River
2024 Fall Planning Work Session
 November 19, 2024; 1:30PM – 3:30PM
 1000 E. Port Marina Drive

AGENDA

- | | | |
|-------------|--|-----------|
| I. | Welcome & Introduction (<i>Kristi Chapman, President</i>) | (2 min.) |
| II. | Meeting Overview (<i>Kevin Greenwood, Executive Director</i>) | (3 min.) |
| | a. <i>Review of Spring Planning Directives and the FY25 Budget (Page xx)</i> | |
| III. | Current Financial Overview (<i>Debbie Smith-Wagar, Finance Director, Page xx</i>) | (25 min.) |
| | a. <i>Review of FY23-24 Financials (Page xx)</i> | |
| | b. <i>Review of July/August 2024 Budget vs. Actuals (Page xx)</i> | |
| | c. <i>Proposed Rates, Fees, and Charges Resolution (Page xx)</i> | |
| | d. <i>10-year Forecast (Page xx)</i> | |
| IV. | Key Issues for FY 2024-25 | (40 min.) |
| | a. Existing Bridge | |
| | ○ <i>8-year CIP (Klapprich, Pg. 83)</i> | |
| | ○ <i>Market BreezeBy Program to New Clients (Greenwood, Pg. 83)</i> | |
| | ○ <i>USCG Rule Change for Mariner Lift Request (Greenwood, Pg. 67)</i> | |
| | b. Marina/Waterfront Recreation Sustainability | |
| | ○ <i>Waterfront Sustainability Plan (Greenwood, Pg. 71)</i> | |
| | ○ <i>Waterfront Access/Parking (Greenwood, Pg. 73)</i> | |
| | ○ <i>CAT/Mt. Hood Meadows Winter Operations (Stafford, Pg. 73)</i> | |
| | c. Airport Sustainability | |
| | ○ <i>Develop So. Apron T-Hangars (Greenwood, Pg. 87)</i> | |
| | ○ <i>No. Apron Development Progress (Greenwood, Pg. 91)</i> | |
| | ○ <i>AWOS Project (Safety) (Greenwood, Pg. 91)</i> | |
| | d. Developable Land | |
| | ○ <i>Storage Facilities at Lower Mill (Greenwood, Pg. 107)</i> | |
| | ○ <i>Roundabout at Second and Riverside/Lot 1 (Greenwood, Pg. 109)</i> | |
| | ○ <i>Commercial Zoned Property (Greenwood, Pg. 109)</i> | |
| | e. Existing Buildings | |
| | ○ <i>Outsource Leasing Services (Greenwood, Pg. 113)</i> | |
| | ○ <i>Sell Big 7 Building & Identify Use of Proceeds (Greenwood, Pg. 113)</i> | |
| | f. Bridge Replacement | |
| | ○ <i>Transition Plan for Port off Tolls for Non-Bridge Activities (Greenwood, Pg. 83)</i> | |
| | ○ <i>Prepare for Bridge Construction (Greenwood, Pg. 83)</i> | |
| | ○ <i>Admin Building Relocation (Greenwood, Pg. 85)</i> | |
| V. | Other | |

This page intentionally left blank.



2024 Columbia Gorge Annual Economic Symposium

November 1, 2024, 8:00 a.m. to 12:30 p.m.
Fort Dalles Readiness Center, The Dalles

DRAFT Agenda

- 8:00 a.m. Full Breakfast (included) and Networking
- 9:00 a.m. Welcome Remarks from Mid-Columbia Economic Development District
- 9:15 a.m. Keynote Presentation from Helen Price Johnson, Washington State Director of USDA Rural Development
Including Audience Q&A
- 10:00 a.m. Summary of our Regional Economy Trends and Forecasts
Including Audience Q&A
- 10:45 a.m. Gorge Main Street Business Panel: Challenges and Opportunities
- Melissa Still, Big Foot Coffee Roasters, Stevenson, WA
 - Kaahreana Ochoco, Vibe Consignment, The Dalles, OR
 - Lucy Gorman, Lucy's Informal Flowers, Hood River, OR
- Including Audience Q&A*
- 11:30 a.m. Gorge Agriculture Panel: Impacts and Shifts with a Changing Climate
- Rachael Horn, wine grapes, Underwood, WA
 - Joe Dabulskis, wheat, Sherman County, OR
 - Jennifer Euwer, pears, Parkdale, OR
- Including Audience Q&A*
- 12:15 p.m. Closing Remarks
- 12:30 p.m. Adjourn

With Appreciation for our 2024 Sponsors:

Columbia River Insurance NW Natural
The Dalles Area Chamber of Commerce Umpqua Bank
US Economic Development Administration

This page intentionally left blank.



**Meeting Notes &
Initial outline of work needed to evaluate new Port Office location
9/30/2024**

Client: Port of Hood River
Meeting date: September 24, 2024 (web meeting)
Attendees: Kevin Greenwood, Eric Hoffman, Kelley Wilson

The virtual meeting focused on the upcoming process to relocate the Port headquarters.

- Airport/FOB. It currently is not profitable; port will subsidize it about \$250K this year. Relocating the port HQ at the airport along with a potential new FEMA Emergency Operations Center could provide momentum and synergy.
- The port is currently soliciting real estate services. These will be critical relocation process, i.e. identifying potential site, buildings, etc. based on programmed needs.
- An interim HQ relocation should be considered and vetted as part of the process.
- POHR has completed the condition assessment of port properties/buildings (inventory). SDSA needs a copy of this report.
- Approx. half of current port staff works on bridge such as toll takers. Programming should be looked at in terms of pre-new bridge and post-new bridge staffing.

The task at hand will be to develop process steps and final scope to be reviewed/approved by the commission and Kevin. Then provide SUM fee.

Initial Outline of Scope of Work

High level tasks/steps

1. Programming (pre and post bridge)
2. Criteria development (interim and permanent)
3. Initial screening
4. Final decision criteria
5. Property identification & analysis
6. Final report

Step 1: Programming.

- a. Short Term (during bridge construction)
 - i. program, needs, adjacencies
- b. Long Term (after bridge completion)
 - i. program, needs, adjacencies.
 - ii. What services are deleted?
- c. Do all three large elements need to be together (office, shop, yard)?
- d. Initial review of current Port property inventory condition report and review bare

land properties. This report was just recently generated.

Step 2: Criteria Development (interim and permanent).

- a. Zoning (verify Port use will work at property)
- b. Condition of building / space / land
- c. Upgrades needed / required
- d. Use of space restrictions (landlord)
- e. Financial
 - i. Cost to operate
 - ii. Rent / CAM
 - iii. Existing costs and capital needs
- f. Port Property - is it performing and evaluate viability for general market rentability
- g. Port Property – future development potential i.e. does a location have higher future usage than Port office space or have future higher revenue generation than what the Port can/want to pay.
- h. Future scalability – covenants that are symbiotic with the Port and the ability to grow
- i. Access to public– today toll payers, but future might be ticket appeals, marina users (rent or maintenance issue) and airport users.
- j. Parking for staff of office, parking for maintenance, shop staff
- k. Costs: move costs (twice), TI or build cost, rent cost over set period of time.
- l. Level of effort – construction (TI vs New) and time. Zoning and Compliance (entitlement effort)

Step 3: Initial Screening / Evaluation

- a. Meet with new commercial real estate agent / firm (CRA)
- b. Evaluate general Hood River market conditions – what is available to rent?
- c. Create full list of space/buildings/land on the market including Port properties
- d. Short Term – is space move-in ready with little to no improvements

Step 4: Final Decision Criteria

- a. Cull criteria list based on Step 3 and Board input.
- b. Decide what items are weighted more heavily
- c. Create matrix

Step 5: Property Identification & Analysis

- a. Take the property list in Step 3 and the final criteria in Step 4, start the trimming process.
- b. Create short list of viable properties that will run through the criteria list
- c. Final ranking of properties

Step 6: Report

- a. Create a final report that showcases each of the final viable properties
- b. Report is to show each property and how is ranked against the criteria
- c. This may want to be in conjunction with CRA so the report can include rent costs
- d. This may want to be in conjunction with a Cost Estimator so we can show TI costs, move costs, new build costs, etc....



Assumptions:

- a. Both Port and General Market properties are under consideration
- b. It would be helpful to identify a financial consultant to analyze costs of construction, building and moving.
- c. CRA can address leases costs, opportunity cost of lost revenue if HQ uses a currently owned port building, etc.



See following list for generic criteria for selecting commercial building relocation as initial starting point. We would use this as part of the Criteria List generation.

Selection Criteria

1. Location

- Visibility: Visibility from major roads or intersections.
- Accessibility: Ease of access for customers and employees, including public transportation options.

2. Market Conditions

- Current Market Trends: Analyze supply and demand dynamics, including vacancy rates and rental rates.
- Future Development Plans: Research upcoming developments in the area that could impact property value.

3. Property Type

- Suitability for Use: Ensure the property type aligns with business model (e.g., office, retail, industrial).
- Flexibility: Evaluate the adaptability of the space for future needs.
- Size: Evaluate property size to accommodate needs and future growth.

4. Financial Analysis

- Purchase Price or Lease Terms: Assess whether the price reflects the market value.
- Operating Expenses: Understand costs related to maintenance, utilities, insurance, and taxes.
- Return on Investment (ROI): Calculate potential ROI based on rental income, appreciation, and expenses.

5. Building Condition

- Age and Maintenance: Evaluate the age of the building and any required renovations.
- Structural Integrity: Check for issues like foundation problems, roofing, and HVAC systems.

6. Zoning and Regulations

- Zoning Compliance: Confirm that the property is zoned for your intended use.
- Local Regulations: Investigate any restrictions or regulations that could affect operations.

7. Demographics

- Target Market: Analyze the demographic profile of the area to ensure it aligns with your customer base.
- Population Growth: Look for areas with increasing populations that could drive demand.

8. Competition

- Market Saturation: Assess the number and type of competitors in the vicinity.
- Differentiation: Identify what sets your business apart from competitors in the area.

9. Amenities and Services

- Nearby Services: Evaluate proximity to essential services such as banks, restaurants, and hotels.
- Infrastructure: Look for the availability of necessary infrastructure, including broadband and utilities.

10. Safety and Security

- Crime Rates: Research local crime statistics and safety measures in place.
- Emergency Services: Consider the proximity and response times of local emergency services.

11. Parking and Transportation

- Parking Availability: Ensure adequate parking for employees and customers.
- Transportation Links: Consider proximity to major transportation hubs (highways, airports).

12. Environmental Considerations

- Site Assessments: Conduct environmental assessments for any contamination or hazardous materials.
- Sustainability Practices: Evaluate existing sustainability features or potential for eco-friendly improvements.

13. Tenant Considerations (for investment properties)

- Lease Terms: Review existing leases for terms and tenant obligations.
- Tenant Creditworthiness: Assess the financial stability and reliability of current tenants.

14. Exit Strategy

- Resale Potential: Evaluate how easy it would be to sell the property in the future.
- Market Trends: Consider the potential for appreciation and changes in market demand.

This page intentionally left blank.



600 E. Marina Dr. (South Basin Dock)

Mail: 2149 Cascade Ave Suite 106A #128 Hood River, OR 97031

www.gorgejuniorsailing.org email: gorgejuniorsailing@gmail.com

September 4, 2024

Gorge Junior Sailing End of Season Report 2024

The 2024 summer sailing season was a big success for Gorge Junior Sailing (GJS) and we would like to thank the Port of Hood River for its continued support and cooperation.

A few main points:

- 159 students enrolled
- 6 weeks of lessons
- Filled a need in the community for ADULT LESSONS
- 0 accidents or injuries
- 0 complaints

As a partner of GJS, the Gorge High School Sailing Team (GST) performed better this year than they have in many years. The Columbia High School team placed 3rd by just one point at the district championship in Anacortes, WA, which qualified them for the Phoebe King Regatta in Annapolis, Maryland. GST sent 4 Columbia sailors to compete on behalf of the Northwest Interscholastic Sailing Association. (NWISA) The Hood River Valley High School Team also finished with a top-10 result at the district championship.

The adult sailing classes we taught this summer were a big hit. They filled an important need in the community. We taught 15 adults how to sail on Club 420s. Based on the popularity and limited marketing we had, in 2025 we expect to double the amount of adult beginner sailors in the program.

For summer 2025, GJS wants to expand our core business - teaching local kids (and adults) to sail! Currently, we operate for only 6-weeks and teach approximately 30 children each week. Our goal is to operate for 8-weeks and teach 40 children per week.

A few things we'd like to implement next year.

1. By expanding the season 2-weeks and getting the marketing out earlier in 2025, we hope to increase participation.
2. We plan to merge forces with the Hood River Yacht Club and Gorge Junior Sailing Team to unite under one leadership board. This will allow the entire Gorge community



600 E. Marina Dr. (South Basin Dock)

Mail: 2149 Cascade Ave Suite 106A #128 Hood River, OR 97031

www.gorgejuniorsailing.org email: gorgejuniorsailing@gmail.com

sailing program to act more efficiently, share resources, and present a more professional, cohesive organization to the Port of Hood River and the general public.

3. We are currently applying to become a US Sailing accredited organization.

Strategic vision:

With the cooperation of the Hood River Yacht Club and the Gorge Sailing Team, we plan to expand our scope to include more accessibility, diversity, clinics, regattas and educational events. Many people around the world consider “The Gorge” to be a famous windsport destination and the Hood River community sailing center is stepping into its role as the prestige competitive windsport organizing authority.

As a US Sailing Accredited Community Sailing Center in 2025, we want to host the following events in addition to the HRYC 1-Design, Double-Dammed, and Memaloose Regattas.

1. High Wind Clinic.
2. Women’s Clinic.
3. Expand on the success of the Wingfoil Race Series.
4. Partner with Wylde Wind and Water’s “Viento y Agua” program to offer the local Hispanic youth population access to sailing instruction.
5. Possibly host a training camp for the US Sailing Team.

In conclusion, Gorge Junior Sailing had a very successful season and would like to again thank the Port of Hood River for its continued support and cooperation to provide sailing access and education to the communities of the Columbia Gorge.

Sincerely,

- Jaime Mack, Executive Director
- Jed Reitman, Program Director

Jaime Mack

Jed Reitman



October 6, 2024

Ryan Klapprich
Facilities Manager
Port of Hood River
via Email: Rklapprich@portofhoodriver.com

Hood River Lift Bridge

Dear Ryan:

The Port of Hood River has requested that we provide a summary of the following:

1. Acknowledging that the rope replacement project is complete and meets engineering guidelines/approve to operate.
2. Findings as to how frequently the span should be lifted and reasons for lifting (or not); and
3. An assessment of whether Port staff has enough people trained to conduct the lift and guidance for continued training.
4. A sentence or two with recommendations

Each of these items is addressed in order below.

1. The field work portion of the rope replacement project is complete, all work is acceptable, and the bridge is approved to operate. We are still waiting on "As Built" drawings from the contractor. We anticipate that the "As Built" drawings will be provided within the next week or so.
2. The lift span should be operated monthly. The advantages of monthly operation are as follows:
 - a. Operations personnel will remain familiar with the bridge operating sequence and associated safety features.
 - b. Lubrication will be distributed on the moving parts. This helps to prevent the development of corrosion.
 - c. Periodic operation should be combined with required maintenance activities which are necessary to keep the bridge operating reliably.
 - d. The electrical power and control system contains many relays, contactors and limit switches whose contacts form corrosion without use. Operation of these devices, at least once a month prevents this buildup of corrosion and ensures reliable operation of these devices in the long term.
3. The Port has sufficient staff to operate the bridge. A system is in place for one our engineers and personnel from Panatrol (control systems vendor) to be available via phone for all bridge operations to troubleshoot any problems that may arise during an operation.

The Port staff would benefit from mechanical and electrical training to ensure that the bridge is operated per the correct sequence and to ensure that all required maintenance activities ae

understood. This training can be conducted in one or two days with personnel from WJE. We would provide this training with one mechanical and one electrical engineer both of whom are familiar with the lift span operations and maintenance requirements.

4. We recommend the following:
 - a. Conduct mechanical and electrical training of bridge operations and maintenance staff.
 - b. Operate the Hood River lift span monthly.
 - c. See recent inspection report for additional recommendations.

Sincerely,

WISS, JANNEY, ELSTNER ASSOCIATES, INC.



Paul M. Bandlow
Principal

c: Kevin Greenwood – Port of Hood River
Gareth Rees – WJE



September 2024 Report

Ken Jernstedt Airfield

Hood River, Oregon



September 2024 Aircraft Traffic Count 2542 logged flight activities which was up 200 from August.

Aircraft Type	
Type	Total
Helicopter	168
Jet	2
Multi-Prop	32
Narrow	4
Single-Prop	2288
Unknown	48

<https://aero.motioninfo.com/secure/reports.cfm>

- Staff has been working on the design of the North East ramp building site at length to try to satisfy all of the past concerns as well as the needs while still making the best use of the space for all parties. The attached design idea should cover all of the concerns.
- The AAC meeting had a number of to-do items for the coming months. Please see the attached summary.
- AMS Staff attended the Oregon Aviation Managers Association conference in Eugene, getting some great face to face time with our FAA reps as well as time with other airport managers, who are all facing the same challenges that we are. I have also attached some of my takeaways from this event.
- The grounds were mowed and weed whacked in the days previous to the Fly In, I had the Port staff and the contractors mow the grass runway on the Thursday morning prior to the event. The speed of this mowing was impressive. I had the runway closed and monitored it for traffic.
- *Hangar Break in:* I have met with Pacific Power & Light and have a plan together to get lighting into some of the darkest areas of the airport. The Camera bid and information has not come back in yet.
- *The current AWOS grant is having a new scope of work approved to study the removal of the trees or the relocation of the weather equipment. If it is found that the trees being removed will eliminate the wind anomaly the FAA may be able to assist in the cost of removal.* I met with the tree removal crew and came up with a partial plan, to get the trees out we would need to go north thru the Terry Brandt property, I need to have a bit of time with Terry to discuss this. The process will not need to happen until we have the AWOS study completed. The estimate was \$1800-2000 a day and they figured a week of work would be needed. We shall get the study done and if needed I will be finding funds (FAA or State) to assist with this.
- *I met with the FBO staff to explore some possible landscape ideas for beautifying the FBO area. They and I will be working on the costs associated and the requirements of the leased areas being maintained by the FBO staff.* Still working on some design and quotes.

- I met with the USFS Helicopter contractor that was operating from the North Ramp. We were able to bill \$1600 in a land use agreement (LUA) with them and have established some criteria for the next season.



- *Working with PAE to redesign the North Apron to get 2 more rows of Tie Downs for airplanes. This is an eligible project for some funds that need to be used along with the rehab of the pavement between the north side hangars. (reflected in the CIP notes below)* All of this is in conjunction with the North Ramp building sites that we are working thru now, making sure the planning is accurate for the highest and best use of the limited space we have.
- *I also had the FAA reach out and ask for an appointment to meet and look at the airport for the possibility of adding some DME (distance measuring equipment) to our airport. I should be meeting with them around the 19th.* This was an interesting meeting that may see some traction, yet not for a few years (the speed of Govt. planning) If it was to happen it will have little to no effect on the airport.



Another Beautiful day at the Airport!!

Jeff Renard

Airport Manager

Columbia Gorge Regional Airport

Aviation Management Services (AMS)

jrenard@aviationmanagementservice.com

Cell: 541-288-6766



4S2 Operations Summary 9/1/2024 - 9/30/2024

Aircraft Counts

Based Aircraft Operations:	0
Itinerant Aircraft Operations:	2500

Operations Per Year

Year	Total
2024	8919
2023	9012
2022	4304
2021	4246
2020	5143
2019	9593
2018	7370

Operations Per Month

Month	Total
October 2024	295
September 2024	1293
August 2024	1175
July 2024	1337
June 2024	1430
May 2024	978
April 2024	786
March 2024	937
February 2024	571
January 2024	117
December 2023	243
November 2023	482
October 2023	746

September 2023	1480
August 2023	893
July 2023	1115
June 2023	957
May 2023	999
April 2023	743
March 2023	499
February 2023	515
January 2023	340
December 2022	65
September 2022	978

Operations by Category					
Category	2020	2021	2022	2023	2024
Air Taxi	160	126	183	601	613
Local GA	52	13	12	21	56
Itinerant GA	4919	4107	4109	8388	8250
Itinerant Military	12	0	0	0	0

Top Manufacturers & Models		
Manufacturer	Model	Total
CESSNA	C182	286
CESSNA	C172	220
PIPER/CUB CRAFTERS	PA18	112
CESSNA	C150	90
CESSNA	C206	82
CESSNA	C170	68
HAAN ROBERT A	RV6	68
PIPER	PA18	64
CESSNA	C152	60
VASHON AIRCRAFT	RR7	58

BELL TEXTRON CANADA LTD	B407	52
MAULE	M4	52
PIPER	PA18	52
MOONEY	MO20	48
CESSNA	C185	44
EUROCOPTER	AS50	44
PIPER	P28A	44
BEECH	BE35	40
BEECH	BE33	38
CESSNA	C206	38
MORRISEY	M215	38
VANS AIRCRAFT INC	RV12	36
BELLANCA	CH7A	34
L-BIRD LLC	PA18	32
CESSNA	C120	30
CESSNA	C175	26
CESSNA	C180	26
AMERICAN EUROCOPTER CORP	AS50	24
CIRRUS DESIGN CORP	SR22	24
CUB CRAFTERS	PA18	24
UNKNOWN		20
CUB CRAFTERS INC	CC19	18
JOHN M TOUDOUZE	ULAC	18
LEROUX JOHN F	PA18	18
PIPER	PA22	16
PIPER	PA24	16
UNIVERSAL	GC1	16
UNKNOWN	ESCP	16
CUB CRAFTERS INC	CC19	14
MAULE	MXT7	14
BEECH	BE23	12

BELL	B407	12
BOEING	ST75	12
CESSNA	C310	12
BEECH	BE36	10
R PAUL MARKT	CRER	10
ROBINSON HELICOPTER	R22	10
WERNER RUSSELL D	HROC	10
UNKNOWN	T206	9
AGUSTAWESTLAND PHILADELPHIA CO	A119	8

Aircraft Approach Category & Design Group

Category & Group	Total
A-I	987
A-II	6
B-I	33
C-I	9
C-III	1
C-IV	1
D-I	11
E-I	4
UNK	270

Aircraft Type

Type	Total
Helicopter	168
Jet	2
Multi-Prop	32
Narrow	4
Single-Prop	2288
Unknown	48

Engine Type

Type	Total
4 Cycle	338
Electric	8
Reciprocating	1880
Turbo-fan	2
Turbo-prop	12
Turbo-shaft	102
Unknown	200

Airline Code

Code	Total
CAP	4
GA	2193
UNKNOWN	345

MotionInfo
PO Box 612, Orleans MA 02653

+1 (401) 247-7780
support@motioninfo.com

This page intentionally left blank.

INDUSTRIAL/COMMERCIAL FACILITIES • AIRPORT • INTERSTATE BRIDGE • MARINA

1000 E. Port Marina Drive • Hood River, OR 97031 • (541) 386-1645 • Fax: (541) 386-1395 • portofhoodriver.com • Email: info@portofhoodriver.com

AIRPORT ADVISORY COMMITTEE

Thursday, September 19, 2024

4:00-5:30 pm

PORT CONFERENCE ROOM.

(Chair: Dave Koebel - Vice-Chair: Margo Dameier)

1. Roll Call and Introductions 5 min.
2. Additions/Modifications to Agenda 5 min.
3. Approval of Minutes 5 min.
4. FY25 Airport Budget/Fees 20 min.
5. Project Updates 20 min.
 - Traffic counts
 - Tree survey / AWOS
 - FAA CIP
6. Discussion topics 20 min.
 - Minimum Standards – Committee’s review/comments
 - Crime / break ins / Security enhancements
 - Calm Wind Runway determination
 - AAC terms Resolution
7. Stakeholder Updates 15 min.
 - i. FBO
 - ii. WAAAM
 - iii. HR Soaring
8. New Business/Public Comment 15 min.

Adjourn

AIRPORT ADVISORY COMMITTEE AMS Task List

Thursday, September 19, 2024

- Confirm the AWOS install date and is there any wind data before the trees grew?
- Would the runway overrun be “eligible” pavement for future FAA funds?
- Try to change lighting on A & B rows to not shine at Jeanette rd.
- Research motion sensors to be installed on north ramp lights
- Eliminate the “07 Calm wind runway” from all documents and signs. Tor to add to consent agenda
- Confirm the sewer connections on the north ramp with John Clark at Hood River sewer.
- Move future meetings to the week or 2 before the Port Commission meeting. (Nov. 7)
- Review Minimum Standards
- AWOS message to be reviewed by pilots prior to being put up.



OAMA

Oregon Aviation Management Association 2024 Conference notes

- Kengi with Oregon Dept. of Aviation gave a report on the new jobs in the aviation sector in the Eugene market, direct and indirect (1226)
- Kengi also visited many airports and shared new perspectives and ideas about implementing drones into the market.
- Oregon considering an increase in the Jet fuel tax rate, has not been increased since 1955
- Drone operators are soon to be required to have commercial insurance. Homeowners insurance will not cover the aviation components.
- ODAV website to have changes soon/ Revenue & grants all available on the website.
- AAM Companies (who should we be courting) **Zipline, Joby, Wisk, Archer, Beta, Sagetech**
- Warren Farrel Director of the (Seattle ADO) on extended leave.
- 2025 Grants to have 95% match instead of 90%
- CIP Data conversations with Tim House and discussion about the EDA project and future NEPA requirements depending way we acquired the airport or if we have encumbered it with federal grants.
- FAA grant assurances to require that airports keep 100LL as a fuel source at least thru 2030. (Good news for now)
- Research the “compost filtration” along with the onsite infiltration
- Send all future “2026 dreams” to Adam Merrill at least 6 months in advance so that he may start the exercises needed to be ahead of the NEPA components.
- Reach out to Matt Josal about the ASOS / AWOS system and see if there is anything we can do for upgrades??



AVIATION MANAGEMENT SERVICES

- F.I.N.S. Fiber Optic through airports??
- The Governor Directed all agencies to provide a budget with not more than 1% increases for the next budget.
- The ODOT budget shortfall is projected to be \$4 billion.
- WE really need to focus on becoming a true resiliency hub.
- Look up Janine Solomon and her bill on 100LL
- Damon Runberg with Biz Oregon / Who is my RDO?
- Research Initiative 118
- 4S2 needs SWAG and Community Advertising signs on water tanks?
- Great conversations with FAA staff on many airport topics..... I was also asked to speak at next year's OAMA about my small business perspective and how to help other airports do what we are doing here. By thinking out of the box and having “shovel ready” projects and an ability to have your match money. Our **T hangar and turf taxiway** was used as an example of thinking out of the box to keep the airport moving forward at the convention.
-



AVIATION MANAGEMENT SERVICES

4S2 FBO Report | September 2024

Airport Activity:

September proved to be a great month in terms of total flight operations. This was mostly due to the WAAAM Fly-In.

Aircraft Operations

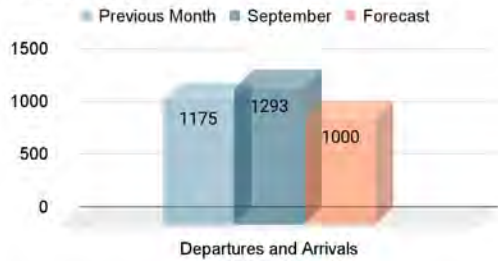

Night Flights:

No night flights flown in September. No large events scheduled for October.

Night Events



Flight Training: 15 training events were conducted by Hood Aero in September. No other training events have been reported.

Flight Training Events



Maintenance Activity:

10 total maintenance events took place in September. 2 inspections took place while 8 unscheduled maintenance events took place

Maintenance Events

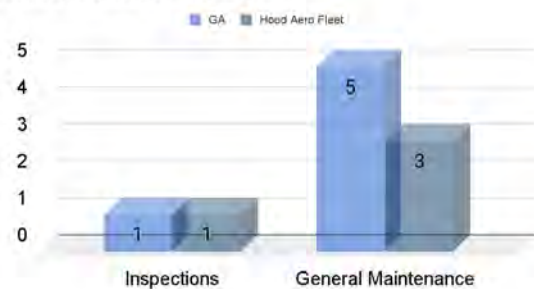

Fuel Sales: The Fly-In was not as well attended as expected due to smoky conditions. Fuel sales were less than last year's Fly-In but still above average. October will show a decline in fuel sales as the seasons change.

Fuel Sales (Gallons)

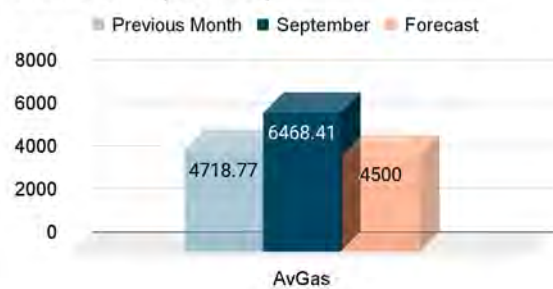

Fuel Flowage Fees:

\$646.84 paid in flowage fees to the Port of Hood River in July. Based on .10 per gallon and a rounded sale of 6468.41 gallons.

Tie Down Activity:

- 23 total spots.
- 70% utilization for August averaged.
- \$0 collected for tie down fees in A.

Noise Feedback:

No noise complaints received by the FBO in September.

Pilot Feedback:

Feedback was given in regards to an AWOS message related to the glider aerobatic area. In the future, when the glider aerobatic area is active, a message will be put on the AWOS stating "Glider aerobatic practice area is active. See NOTAM".

Airport Surfaces:

	Condition	Notes.
Rwy 7/25		
Grass Strip		
N. Ramp		
S. Ramp		
S. Gravel		
Taxiways		

Facilities:

	Condition	Notes.
N. Hangars		
S. Hangars		
FBO		
MX Hangar		
Ops Hangar		

Collins Hangar		
Blue Hangar		

Lighting:

- No issues noted with airport lighting.

Other:

- No other issues noted.

Commission Memo

Prepared by: Debbie Smith-Wagar, Finance Director
Date: October 15, 2024
Re: Port of Hood River Employee Handbook Update



The Port of Hood River has undertaken a crucial update to its Employee Handbook to align with current legal standards and enhance employee satisfaction and operational efficiency. Since its last revision in 2018, significant legislative changes and operational challenges, exacerbated by the pandemic, necessitated a comprehensive update to better serve our workforce. The Port collaborated with HR Answers, SDAO HR Manager, Personnel Committee and Port’s Legal Counsel to ensure the handbook remains relevant, legally compliant, and supportive of our workforce.

We understand that the handbook is a substantial document; however, it is necessary as it consolidates all of our HR policies in one place, providing a comprehensive resource for employees and management alike. Where possible, we have made efforts to be concise without sacrificing clarity or legal compliance.

Key Updates and Enhancements:

1. Legal Compliance:
 - Updates include amendments to Family and Medical Leave, Oregon Family Leave policies (effective July 1, 2024), and Paid Leave Oregon policy (effective 2023). These updates ensure clarity and legal compliance for employee rights and protections.
2. Paid Time Off (PTO) Policy Enhancements:
 - We have streamlined our PTO policies by consolidating sick leave and vacation banks into a unified Paid Time Off program. In addition, three personal holidays have been added to the floating holidays. This adjustment offers employees greater flexibility in managing their time off while maintaining legal provisions for health-related absences.
3. Flexible Scheduling:
 - In response to varying employee needs and operational demands, flexible scheduling options have been introduced. This initiative supports work-life balance and operational efficiency without compromising service delivery.
4. Value-Based Compensation:
 - A new Value-Based Compensation program has been introduced to incentivize professional development and certification. This initiative aims to attract and retain top talent by recognizing specialized skills essential to our operations. Compensation values are determined annually by the Finance Department during the budget process.
5. Other Policy Improvements:
 - Updated per diem policies aligned with IRS regulations reduce administrative burdens and ensure compliance.
 - Revised comp time tracking allows for accrued overtime to be saved and used during quieter periods, addressing seasonal work demands effectively.

The Comparison of Old Handbook vs. New Handbook in Matrix Form is attached.

Several of these updates, including enhancements to PTO policies and the introduction of the Value-Based Compensation program, were discussed during the Fall Planning Session in November 2023. The session provided valuable insights and feedback from the Commission, contributing to the refinement of these policies.

These revisions underscore our commitment to fostering a supportive and compliant work environment at the Port of Hood River. As we navigate significant legislative changes and operational challenges, including the impending changes related to the Hood River- White Salmon Bridge, our organizational structure is evolving. It is crucial that we invest in developing our staff to ensure the Port remains an integral piece of our community's infrastructure and economy.

The upcoming changes to the Hood River – White Salmon Bridge underscore the importance of preparing our workforce for the future. By updating our policies to reflect current legal standards and enhancing benefits and operational flexibility, we are not only enhancing employee satisfaction and retention but also preparing ourselves for the challenges and opportunities ahead.

The Port's legal counsel will be available at the meeting to answer questions.

RECOMMENDATION: MOTION to approve Resolution No. 2024-25-8 adopting the updated Port of Hood River Employee Handbook with the effective date of October 15, 2024.

**Port of Hood River Employee Handbook Update:
Comparison of Old Handbook vs. New Handbook**

<i>Item</i>	<i>Old Handbook</i>	<i>New Handbook</i>	<i>Financial Impact</i>	<i>Notes</i>
<i>Ability to cash out sick leave</i>	Only vacation leave could be cashed out	Sick leave can also be cashed out if the PTO balance remains at 120 hours or more	Estimated at 0-1% increase in payroll costs	Allows more flexibility for employees
<i>Flexible Scheduling</i>	Standard 8-5 work week	Option to work flexible schedules like 4-tens	0% change	No monetary or operations impact on the Port
<i>Value-Based Compensation</i>	Not specified	Flat rate for basic training (e.g., flagger certifications) and percentage increase for advanced training (e.g., Electrician Certification)	Potentially 1-5% compensation increase	Incentivizes professional development
<i>Expense Reimbursement</i>	Expense reimbursement	Per diem rate aligned with IRS limits (\$166 standard rate: \$107 lodging, \$59 M&IE)	Estimated at 0-0.5% increase in expense costs	Simplifies administrative process
<i>Compensation Time</i>	Overtime paid immediately or comp time used only in the same pay period	Allows for comp time to be used during quieter periods at later time	0% change	No monetary impact as overtime must be paid anyway or comp time taken
<i>PTO Accrual Rates:</i>				
<i>1st through 12th month (1st year)</i>	3.08 hours vacation + 3.08 hours sick = 6.16 hours per pay period	3.42 hours vacation + 3.08 hours sick = 6.50 hours per pay period	5.52% increase in vacation accrual	+0.34 hours vacation

<i>13th through 60th month (2-5 years)</i>	3.69 hours vacation + 3.08 hours sick = 6.77 hours per pay period	3.92 hours vacation + 3.08 hours sick = 7.00 hours per pay period	3.40% increase in vacation accrual	+0.23 hours vacation
<i>61st through 120th month (6-10 years)</i>	4.62 hours vacation + 3.08 hours sick = 7.70 hours per pay period	4.62 hours vacation + 3.08 hours sick = 7.70 hours per pay period	0% change	No change
<i>121st through 180th month (11-15 years)</i>	6.15 hours vacation + 3.08 hours sick = 9.23 hours per pay period	6.42 hours vacation + 3.08 hours sick = 9.50 hours per pay period	2.92% increase in vacation accrual	+0.27 hours vacation
<i>181st through 240th month (16-20 years)</i>	6.92 hours vacation + 3.08 hours sick = 10 hours per pay period	6.92 hours vacation + 3.08 hours sick = 10 hours per pay period	0% change	No change

Personal / Floating Holidays

2 Personal Holidays	2 Personal Holidays + 3 Floating Holidays Martin Luther King Jr. Day, Indigenous Peoples' Day, and Juneteenth	Estimated at 0-0.5% increase in payroll costs	Allows greater employee flexibility while honoring important cultural and historical days.
---------------------	---	---	--

Note: The preceding table highlights the most significant changes made to the handbook. It does not include all changes.

PORT OF HOOD RIVER PROPOSED						
Benefit	Type/Description	Quantity	Acc. Rate FT Exempt	Acc. Rate FT NonExmpt	Acc. Rate Part Time	Notes/Recommended Change for FY24-25 Update
Health Insurance	Medical, Dental, Vision, Life/LTD/ADD, FSA, Supplemental options		Yes	Yes	30 hours + Yes	No changes recommended
Retirement	PERS, Deferred compensation options					No changes recommended
Paid Time Off (combined sick leave + vacation leave)	Combined PTO	6.50 hours/pay period (3.42 vacation, 3.08 sick leave)	6.50 hours/pay period (3.42 vacation, 3.08 sick leave)	6.50 hours/pay period (3.42 vacation, 3.08 sick leave)	1 hour Oregon Sick Leave per 30 hours worked. 40 hour carryover cap. Full PTO if consistently works 30+ hours/week	Switching from vacation and sick leave banks to combined PTO. 0.34h Increase in accrual rate
	2-5 Year	7 hours/pay period	7 hours/pay period	7 hours/pay period	same as above	Switching to combined PTO. 0.23 hours increase.
	6-10 Year	7.70 hours/pay period	7.70 hours/pay period	7.70 hours/pay period	same as above	Switching to combined PTO. No change in accrual.
	11- 15 Year	9.50 hours/pay period	9.50 hours/pay period	9.50 hours/pay period	same as above	Switching to combined PTO. 0.27 hours increase.
	16-20 years	10 hours/ pay period	10 hours/ pay period	10 hours/ pay period	same as above	Switching to combined PTO. No change in accrual.
Sick Leave	Combined PTO (see above)	N/A	N/A	N/A	N/A	Combined vacation and sick leave into a PTO model
Holidays	Paid holidays off	9 - New Year's, Presidents, Memorial, Independence, Labor Day, Veterans, Thanksgiving, Friday after Thanksgiving, Christmas				No change

HOOD RIVER COUNTY CURRENT						
Benefit	Type	Quantity	Acc. Rate FT Exempt	Acc. Rate FT NonExmpt	Accumulation Rate Part Time	Notes
Health Insurance	Medical, Dental, Vision, 457 Plan, Flex 125, Life		Yes	Yes	20 hours + Yes	
Retirement	PERS					
Vacation	Paid Vacation - 1st Year	5 days	5 days	5 days	5 days	
	2-5 Year	3.33 hours/pay period	3.33 hours/pay period	3.33 hours/pay period	3.33 hours/pay period	
	6-10 Year	5.0 hours/pay period	5.0 hours/pay period	5.0 hours/pay period	5.0 hours/pay period	
	11-15 Year	6.0 hours/pay period	6.0 hours/pay period	6.0 hours/pay period	6.0 hours/pay period	
	16-20 Year	7.0 hours/pay period	7.0 hours/pay period	7.0 hours/pay period	7.0 hours/pay period	
	20+ Years	8.0 hours/pay period	8.0 hours/pay period	8.0 hours/pay period	8.0 hours/pay period	
Sick Leave	Paid sick leave	8 hours per month up to 40	8 hours per month up to 40	4 hours per payroll period	1 hour of Oregon Sick Leave for every 30 hours worked. 40 hour carryover cap.	
Administrative and Executive Leave	Additional paid time off		40 hours per year	16 hours per year	N/A	Leave days may be taken in 1 hour increments. Possible to convert unused leave to employee VEBA account.
Holidays	Paid holidays off	10 - New Years, MLK, Presidents, Memorial, Juneteenth, 4th, Labor, Veterans, Thanksgiving, Day After Thanks, Christmas				

CITY OF HOOD RIVER CURRENT						
Benefit	Type	Quantity	Acc. Rate FT Exempt	Acc. Rate FT NonExmpt	Accumulation Rate Part Time	Notes
Health Insurance	Medical, Dental, Vision. VEBA, Life, AD&D, FSA					
Retirement	PERS, Deferred compensation options					
Vacation	Paid Vacation - Up to 6 months	5 days	5 days	5 days (prorated to hours worked)		
	6 mos - 2 years	3.34 hours/pay period	3.34 hours/pay period	3.34 hours/pay period (prorated to hours worked)		
	6-10 Year	5 hours/pay period	6 hours/pay period	7 hours/pay period (prorated to hours worked)		
	11-15 Year	6 hours/pay period	7 hours/pay period	8 hours/pay period (prorated to hours worked)		
	16-20 Year	7 hours/pay period	8 hours/pay period	9 hours/pay period (prorated to hours worked)		
	21 Years +	8 hours/pay period	9 hours/pay period	10 hours/pay period (prorated to hours worked)		
Sick Leave	Paid sick leave	8 hours per month no limit	8 hours per month no limit	Pro-rata to time worked.		
Holidays	Paid holidays off	11 - New Years, Presidents, Memorial, 4th, Labor, Veterans, Thanksgiving, Day after Thanksgiving, Christmas, MLK, Columbus				

This page intentionally left blank.

Floating Holiday	Paid personal holiday & floating holiday		5 per year	5 per year		Added 3 floating holidays (MLK, Indigenous Peoples' Day, Juneteenth)
Work on a holiday	Extra pay for work on a holiday		N/A	Double time	Double time	No change.
Wellness Incentive - Payment for Accrued Sick Leave	Allows for PTO balance cash out as long as PTO balance remains at 120 hours or more.					Adopted a wellness incentive policy to reward employees that accrue large amounts of PTO.
Donation of sick leave to fellow employees	Allows for PTO to be donated to a fellow coworker in case of an emergency/hard ship.					Changed sick leave donation to PTO donation.
Bereavement Leave	Paid and unpaid leave	Up to 3 days paid, with 7 additional unpaid days (can use other form of paid leave).				No change.
FMLA/OFLA	Unpaid leave	Up to 12 weeks leave without pay in a calendar year.	Must be employed at least 12 months* - check if new law supercedes this.			FMLA does not apply to organizations below 50 employees which is the Port. OFLA applies. See Personal Leave section.
Jury Duty	Paid leave	Up to 2 weeks, but payments from court have to be remitted to Port.				No change.
Uniform Services Leave and Re-Employment	Unpaid leave, generally. If employed 6 months+, up to 15 days paid leave for military training.	USERRA requirements.				No change.
Pregnancy Disability Leave	Part of OFLA					No change. Part of OFLA
Personal Leave	Unpaid leave for compelling personal reasons, upon approval.					Adopted to assist employees since FMLA does not apply to Port.
Religious Observances Leave						No change.
Crime Victim Leave Policy	Reasonable amount of unpaid leave to deal with health and safety needs. Accrued paid leave and FMLA/OFLA can also apply.	Must work at least 25 hours per week.				Adopted Crime Victim Leave Policy.

Floating Holiday	Paid personal holiday	2 per year				
Work on a holiday	Extra pay for work on a holiday		N/A	Time and 1/2, or compensatory time off.	Time and 1/2, or compensatory time off.	
Wellness Incentive - Payment for Accrued Sick Leave						
Donation of sick leave to fellow employees	TBD					
Bereavement Leave	Paid and unpaid leave	Up to 3 days paid with 2 weeks additional unpaid				
FMLA/OFLA	unpaid leave	Up to 12 weeks leave without pay in a calendar year.	Must be employed at least 12 months* - check if new law supercedes this.			
Jury Duty and Witness Duty	Paid leave, but payments from court have to be remitted to Port.					
Uniform Services Leave and Re-Employment		USERRA requirements.				
Pregnancy Disability Leave	Unpaid leave - disability related	Unpaid leave - disability related				
Personal Leave	Up to 30 days unpaid for compelling personal reasons, upon approval.	Up to 30 days unpaid for compelling personal reasons, upon approval.				
Religious Observances Leave	Unpaid leave for religious holy day/observance	Upon approval of dept. head				
Crime Victim Leave Policy	Use of accrued leave (vacaton or sick)	Must work at least 25 hours per week.				

Floating Holiday	Paid personal holiday	2 - one selected by employee and 1 selected by City Manager for all employees				
Work on a holiday	TBD					
Wellness Incentive - Payment for Accrued Sick Leave	After 5 years of continuous employment, payment for a portion of accrued sick leave.	5-10 years - 5%, 10-15 years - 10%, 15-20 years - 20%, 20 or more years - 25%				
Donation of sick leave to fellow employees	Compensable sick leave may be donated based on the above schedule.					
Bereavement Leave	Up to 3 days paid leave. Employees may use other available leave as well.					
FMLA/OFLA	unpaid leave	Up to 12 weeks leave without pay in a calendar year.	Must be employed at least 12 months* - check if new law supercedes this.			
Jury Duty	Paid leave, but payments from court have to be remitted to Port.					
Uniform Services Leave and Re-Employment		USERRA requirements.				
Pregnancy Disability Leave						
Personal Leave						
Religious Observances Leave						
Crime Victim Leave Policy	Reasonable amount of unpaid leave to deal with health and safety needs. Accrued paid leave and FMLA/OFLA can also apply.	Must work at least 25 hours per week.				

This page intentionally left blank.

Domestic Violence and Accommodation Policy	Reasonable amount of unpaid leave to deal with health and safety needs. Accrued paid leave and FMLA/OFLA can					Adopted Domestic Violence Leave policy.
Value-Based Compensation Model //Education and Training Assistance Programs	Value-Based Compensation aligns employee pay with their value to the organization, incentivizing activities that drive measurable business outcomes and ensuring compensation reflects contributions to company success. // Education Classes, Seminars, Conferences, etc. up to IRS limit.					Adopted Value-Based Compensation. Amount is reviewed during the budget process. // Education Classes, Seminars, Conferences, etc. up to IRS limit
General Leave of Absence without Pay	None. This falls under Personal Leave					N/A
EAP	Employee Assistance Program - Canopy wellness					No change.
Bilingual Pay	part of Value Based Compensation Model					part of Value Based Compensation Model
Compensatory Time	Overtime carried forward as comp time at time + 1/2, up to 40 hours accrued, excess paid out.				N/A	Allows for comp time to be used during quieter periods at later time.
On-Call Compensation	\$200 every pay period					No change.

Domestic Violence and Accommodation Policy	Unpaid leave or accrued sick/vacation leave					
Education Leave: Education and Training Assistance Programs						
General Leave of Absence without Pay						
EAP	Employee Assistance Program - Specific Program is not determined in manual					
Bilingual Pay	\$125 per month for employees that pass proficiency test English/Spanish.					
Compensatory Time	Overtime carried forward as comp time at time + 1/2, up to 80 hours accrued, excess paid out.					
On-Call Compensation						

Domestic Violence and Accommodation Policy	Unpaid leave or accrued sick/vacation leave					
Education and Training Assistance Programs	Paid tuition, books, related materials for classes and programs in the employee's Training and Education program. (Grade C or better required). Membership in professional organizations may also be provided.					
General Leave of Absence without Pay	Leave of absence without pay.	Up to 12 months with City Manager approval.				
EAP						
Bilingual Pay						
Compensatory Time	Overtime carried forward as comp time at time + 1/2, up to 40 hours accrued, excess paid out.					
On-Call Compensation						

This page intentionally left blank.

PORT OF HOOD RIVER
Resolution No. 2024-25-8

A RESOLUTION ADOPTING THE REVISED EMPLOYEE HANDBOOK

WHEREAS, the Port of Hood River provides an employee handbook to all employees to demonstrate compliance with state and federal laws and to provide clear communication with employees; AND

WHEREAS, the handbook had not been updated since 2018; AND

WHEREAS, laws, policies and best practices have changed since the last employee handbook update; AND

WHEREAS, best practice is to do this once a year, via resolution; NOW THEREFORE

THE PORT OF HOOD RIVER BOARD OF COMMISSIONERS RESOLVES AS FOLLOWS:

Adopt the employee handbook, Attachment A.

Adopted by the Board of Commissioners of the Port of Hood River this 15th day of October 2024.

SIGNED

Kristi Chapman, President

ATTEST

Michael Fox, Secretary

This page intentionally left blank.



Employee Handbook

2024-2025

Adopted October 15, 2024
by Resolution No. 2024-25-8

TABLE OF CONTENTS

INTRODUCTION	6
MISSION, VISION, & VALUES	7
ABOUT THIS HANDBOOK	7
EMPLOYMENT POLICIES	9
EMPLOYMENT RELATIONSHIP	9
At-Will Employment.....	9
Equal Employment Opportunity (EEO) Policies.....	9
Equal Employment Opportunity.....	9
Employment Eligibility Verification	9
Outside Employment	10
Criminal Arrests and Convictions	10
Americans with Disabilities Act	10
Requesting an Accommodation.....	11
Pregnancy Accommodation Policy	11
No Discrimination, No Retaliation	12
No-Harassment Policy.....	12
Sexual Harassment	12
Other forms of Prohibited Harassment.....	13
Workplace Violence	13
No-Bullying Policy	14
Reporting Incidents of Harassment/ Bullying	14
Other Employee Rights	16
Reporting Improper or Unlawful Conduct - No Retaliation.....	16
Policy Against Retaliation.....	17
Political Activity	17
DISPUTE RESOLUTION PROCEDURE	17
RECRUITMENT PROCESS.....	18
Internal Recruitments	19
Employment Applications and Reference Checks	19
Employment of Relatives	19
Employment Motor Vehicle Record Checks	19
Introductory Period	20
Promotions and Transfer Training Period.....	20
Re-employment	20
Credit for Prior Seniority.....	21
Employment Classifications	21
EMPLOYMENT RECORD KEEPING	22
Access to Personnel Files.....	22
Updating Personnel Records	22
EMPLOYEE RELATIONS & ETHICS	23
ETHICS.....	23
Public Officials.....	23
Gifts	23
Use of Official Position or Office.....	23
Honoraria	24
Financial Interest in Public Contracts.....	24
CONFIDENTIALITY.....	24
Organization and Customers	24
Employee Records	25
WORKPLACE RULES.....	25
Workplace Professionalism	25
Attendance, Punctuality and Reporting Absences.....	26

Off-Duty Conduct.....	26
Open Door Policy.....	26
Interpersonal Communications.....	27
Workspace Bulletin Boards & Announcements.....	27
Subpoena and Deposition Response Procedure.....	27
Charitable Activities and Solicitation.....	27
Children in the Workplace.....	27
Pets in the Workplace.....	27
Whistleblower Protection.....	27
PROFESSIONAL APPEARANCE AND DRESS CODE POLICY.....	28
Commitment to Respect and Individuality.....	28
Professional Appearance Standards.....	28
Business Casual Dress Code.....	28
Department-Specific Guidelines: Uniforms and Port Logo Clothing.....	28
COMMUNICATIONS AND SOFTWARE SYSTEMS POLICY.....	29
Electronic Communications Systems.....	29
Email System.....	29
Software and Hardware Use.....	29
Unauthorized Access.....	30
Laptop Security.....	30
Mobile Devices.....	30
Internet Use.....	30
Social Media Policy.....	30
Voice Mail System.....	32
Telephone Usage, Cell Phones and Mobile Devices in General.....	32
Employee Use of Port - Provided or Paid for Mobile Devices.....	32
Mobile Devices and Public Records.....	32
Use of Generative Artificial Intelligence (AI) Systems.....	33
Public Records.....	33
PERFORMANCE MANAGEMENT AND REVIEW POLICY.....	33
Objectives of the Annual Performance Review Process.....	33
Responsibilities of Managers.....	34
Employee Participation.....	34
Evaluation Schedule.....	34
Evaluation Tools and Documentation.....	34
Evaluation Outcomes.....	34
Continuous Feedback and Improvement.....	35
Recognition and Rewards.....	35
Conflict Resolution.....	35
Training for Evaluators.....	35
Use of Technology.....	35
Alignment with Organizational Goals.....	35
CORRECTIVE ACTION.....	35
COMPENSATION.....	37
PAY EQUITY.....	37
PAY PRACTICES.....	37
Merit-Based Step System.....	37
Paydays.....	38
Payroll Deductions.....	38
Pay Advances.....	38
Method and Delivery of Payment.....	38
Employee Withholding Allowance Certificates (Form W-4).....	38
Final Paycheck.....	38
Paycheck Errors.....	39

HOURS OF WORK AND WORK SCHEDULES	39
Four-Tens Workweek Model	39
Time Records	39
Overtime and Compensatory Time	39
Holiday Pay and Truck Roll	40
On-Call Compensation	40
Meal and Rest Periods	40
Rest Breaks for Expression of Breast Milk.....	40
Social and Recreational Activities	41
Inclement Weather Attendance: Office Closure for Normal Business.....	41
Inclement Weather Attendance: Office Open for Normal Business	41
Inclement Weather Attendance: Office Closed Early	42
TELEWORK OR TELECOMMUTE	42
Information Technology	42
Security	43
Physical Security	43
Technology Support	44
EMPLOYEE-INCURRED EXPENSES AND REIMBURSEMENT	44
Expense Reimbursement Procedure and Reports	44
Mileage Reimbursement	44
Credit Card Payment.....	44
Overnight Travel and Meal Expense Reimbursement	44
Exceeding Per Diem Limits.....	45
Alcoholic Beverages	45
Transportation Expense Reimbursement	45
Spouse/Guest Expense Reimbursement	45
BENEFITS	46
ADDITIONAL COMPENSATION: BENEFITS	46
Benefit Pro-Ration and Employee Cost Sharing	46
Benefit Design and Modification	46
Benefit Plan Documents	46
Benefit Changes and Continuation	46
HEALTH INSURANCE BENEFIT	47
Medical, Dental, Vision Insurance Overview	47
COBRA.....	47
Life, LTD, ADD.....	47
Flexible Spending Accounts.....	47
OTHER INSURANCE BENEFITS	47
State Unemployment Insurance.....	47
Workers' Compensation	48
Return to Work.....	48
Early Return to Work	48
Overlap with Other Laws	48
PAID TIME OFF (PTO) POLICY	49
PAID HOLIDAY BENEFIT	51
OTHER BENEFITS	51
Employee Assistance Program.....	51
Retirement Plan	52
Oregon Savings Growth Plan	52
Uniforms, Boots, and Rain Gear	52
Education and Training Assistance Program	52
Value-Based Compensation for Specific Training and Certifications	53
LEAVES OF ABSENCE	55
BEREAVEMENT LEAVE	55

CIVIC DUTY LEAVE.....	56
Jury or Witness Duty Leave.....	56
Voting Leave.....	57
CRIME VICTIM'S LEAVE & DOMESTIC VIOLENCE LEAVE.....	57
Crime Victim Leave Policy.....	57
Domestic Violence Leave and Accommodation Policy.....	57
FAMILY AND MEDICAL LEAVE (OFLA).....	58
LEAVE TO DONATE BONE MARROW.....	61
PERSONAL LEAVE OF ABSENCE.....	61
MILITARY LEAVE.....	62
PAID LEAVE OREGON.....	63
PAID LEAVE DONATION PROGRAM.....	65
HEALTH AND SAFETY.....	66
Safety Rules and Regulations Development.....	66
Employee Responsibilities.....	66
Reporting Injuries and Illnesses.....	66
Safety Rules and Regulations Communication.....	66
Smoking and Tobacco Use in the Workplace.....	66
SUBSTANCE ABUSE AND ALCOHOL.....	66
Prohibited Conduct.....	67
Prescription and Over-the-Counter Drugs.....	67
Testing for Substance Use.....	67
Drug Testing Procedure.....	68
Refusal to Test or Cooperate.....	68
Search of Property.....	68
Last-Chance Agreement.....	69
Consequences of Positive Test Results or Policy Violations.....	69
Confidentiality.....	69
Employee Assistance.....	69
WORKPLACE SAFETY.....	69
Commitment to Safety.....	69
Prohibition of Weapons.....	69
Reporting Safety Risks.....	69
Conducting Investigations.....	70
Familiarization with Security Systems.....	70
Corrective Action.....	70
Search of Property: Port and Private.....	70
EMERGENCY RESPONSE.....	71
Emergency Situations.....	71
Employee Compensation During Emergencies.....	71
Reporting Threats.....	71
Fires and Emergencies.....	71
Accidents.....	71
Safety Program.....	71
EMPLOYMENT SEPARATION.....	72
Types of Separation.....	72
At-Will Employment.....	72
Resignation.....	72
Job Abandonment.....	72
Job Elimination and Reduction in Work Hours.....	72
Termination.....	72
Exit Interview.....	73
Return of Port Property.....	73
Handbook Receipt Acknowledgment Form.....	74

INTRODUCTION

WELCOME TO THE PORT OF HOOD RIVER

I would like to take this opportunity to welcome you to the Port of Hood River. We trust that your employment with our agency will be a mutually rewarding experience.

The Employee Handbook outlines the Port's personnel policies. The handbook should prove to be very helpful in explaining the Port's approach to these matters and is intended to establish clear expectations and consistent practice. Recognizing that employees are the foundation of any successful organization, our publicly elected Board of Commissioners has consistently supported developing personnel policies that enable the Port to attract, develop, and retain outstanding staff.

Along with an open-door policy, we encourage active communication. Please feel free to discuss any questions you may have about any of these topics with your direct supervisor.

The Port is committed to providing challenging and interesting work, encouraging professional development and growth in our staff, holding ourselves to high professional and ethical standards and celebrating our many successes. We value our staff tremendously, and we cannot separate the success of our employees as professionals with the success of the Port as an organization.

Again, to new employees, welcome aboard. To those current employees simply receiving an updated handbook, we greatly appreciate your continued service.

Sincerely,

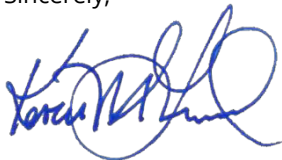

Kevin M. Greenwood
Executive Director



MISSION, VISION, & VALUES

Mission

The Port of Hood River works to promote and maintain a healthy economy and strong quality of life in the Port District and throughout the Columbia Gorge.

Vision

The Port of Hood River fosters commerce and recreation while providing outstanding environmental and fiscal stewardship.

Values

- **INTEGRITY:** Maintain a high level of professional standards.
- **RESPONSIVENESS:** Act in a timely way to all reasonable requests.
- **TRANSPARENCY:** Ensure business is conducted openly, with public oversight.
- **COLLABORATION:** Actively participate with stakeholders.
- **STEWARDSHIP:** Seek high standards of maintenance of the Port's assets and always consider the long-term public good.
- **INNOVATION:** Consider new approaches and best practices.
- **QUALITY:** Strive for excellence in all Port activities.
- **DIVERSITY:** Be proactive, not reactive, in encouraging diversity, equity, and inclusion at all levels of Port activity: Commission, staff, volunteer boards, and public engagement.

ABOUT THIS HANDBOOK

This handbook is designed to be a comprehensive guide to the policies, procedures, and practices governing employment matters at the Port. It is crucial for all Port employees to familiarize themselves with its contents, keep a copy for reference, and review it regularly. Should any questions or need for clarification arise regarding the handbook or its policies, employees are encouraged to reach out to their supervisor or the Human Resources delegate.

The handbook offers general information and guidelines but may not cover every possible scenario or exception to Port policies and procedures. Any modifications to the handbook require a resolution by the Port Commission.

It's important to understand that neither this handbook nor any other organizational document creates contractual rights, whether expressed or implied, regarding continued employment with the Port. Employment at the Port is at-will, meaning either the Port or the employee can terminate the employment relationship at any time, with or without reason or notice.

This handbook supersedes all previous versions, and any prior oral or written agreements, provisions, descriptions, or understandings related to the Port's policies, rules, procedures, and benefits.

Changes in Policy

The Employee Handbook introduces the Port and provides guidance on its overall expectations and policies. The policies outlined within this handbook take effect upon approval by the Board of Commissioners and supersede all other pre-existing policies and practices, whether expressed or implied, written or oral, related to the subjects covered.

To adapt to the evolving needs of its employees and customers, the Port retains the right to make additions, deletions, or other modifications to the provisions and policies of the Employee Handbook as necessary. These changes become effective upon adoption by the Board of Commissioners.

While the Port strives to provide employees with advance notice of any policy changes whenever possible, the absence of notice does not invalidate the implementation of such changes. The Port retains complete discretion in all matters covered by the handbook, including working conditions, disciplinary procedures, policy development, and compensation, except where constrained by law. In all disputes, investigations, or contentious matters, the Port's determination of the facts, made in good faith, shall be considered final. The Port also reserves the right to interpret these policies as situations arise, and its interpretations, made in good faith, shall be deemed final.

If any uncertainty arises regarding a policy or procedure, employees are encouraged to consult their supervisor and/or the Executive Director for clarification. The information contained in this handbook applies to all Port employees and is provided for informational purposes only. Its contents should not be construed as forming a contract between the Port and any of its employees.

EMPLOYMENT POLICIES

EMPLOYMENT RELATIONSHIP

At-Will Employment

The relationship between the employee and the Port is based on an “at-will” employment arrangement. This means that employment at the Port is not for any definite period and may be terminated at any time by either party, with or without reason or advance notice. The timing or manner of wage or salary payments does not alter this at-will status. Only the Executive Director has the authority to enter into any agreement contrary to this at-will relationship. Any changes to this status must be made in writing and signed by both the Executive Director and the employee. The Port is not bound by any oral promises regarding the duration or terms of employment.

Equal Employment Opportunity (EEO) Policies

The following EEO Policies apply to all employees. Members of management, elected officials and employees alike are expected to adhere to and enforce the following EEO Policies. An employee’s failure to do so may result in discipline, up to and including termination.

All employees are encouraged to discuss these EEO Policies with the Human Resources delegate at any time if they have questions relating to the issues of harassment, discrimination, or bullying, or what it means to work in a respectful workplace.

Equal Employment Opportunity

The Port is committed to being an equal-opportunity employer. Employment decisions are made based on an individual’s abilities and performance, without regard to race, age, religion, color, sex, pregnancy (including childbirth and related medical conditions), national origin, physical or mental disability, marital or veteran status, sexual orientation, gender identity, genetic information, domestic violence victim status, or any other classification protected by federal, Oregon, or local law. The Port adheres to all employment requirements mandated by local, state, and federal regulations.

For purposes of this and all other Port policies, “race” is defined to include physical characteristics that are historically associated with race, including but not limited to natural hair, hair texture, hair type and protective hair styles). Further, “protective hairstyles” is defined as “hairstyle, hair color or manner of wearing hair, including braids (regardless of whether the braids are created with extensions or styled with adornments, locs and twists).”

To ensure equal employment opportunities in all aspects of employment and the work environment, the Port employs affirmative measures which refer to the Port’s steps to ensure that equal employment opportunities are upheld and that nondiscrimination policies are enforced in every aspect of the employment relationship, including recruitment, selection, compensation, promotion, transfer, layoff and recall, termination, training, and dispute resolution.

In line with this commitment, all advertising and recruiting materials will include the statement: “Equal Opportunity Employer.” The Port hires those legally entitled to work in the United States without regard to citizenship status, ethnic background, or national origin, in compliance with relevant immigration statutes and regulations. Verification documentation is required for all new hires.

All employees are responsible for upholding this policy.

Employment Eligibility Verification

In compliance with the Immigration Reform and Control Act of 1986 (IRCA), the Port hires only individuals eligible to work in the United States. Verification documentation is mandatory for all new hires, and employees must

promptly notify the Port of any changes in their eligibility status. The Port may use the federal E-Verify program, where permissible by law, to verify social security numbers, or other methods for social security number verification. All verification documents must be current and unexpired, as expired documents are not valid for I-9 purposes.

Outside Employment

Generally, employees may obtain employment with an employer other than the Port or engage in private income-producing activity of their own so long as that activity is not otherwise prohibited by these rules. Employees are responsible for assuring that their outside employment does not conflict with these rules.

An employee is prohibited from, directly or indirectly, soliciting or accepting the promise of future employment based on the understanding that the offer is influenced by the employee's official action.

Employees may not accept outside employment that involves:

- The use of Port time (including the employee's work time), Port facilities, equipment and supplies, or the prestige or influence of the employee's position with the Port. In other words, the employee may not engage in private business interests or other employment activities on the Port's time or using the Port's property;
- The performance of an act that may later be subject to control, inspection, review or audit by the department for whom the employee works (or by a State agency); or
- Receipt of money or anything of value for performance of duties that the employee is required to perform for the Port.

The Port requires employees to report outside employment to their supervisor before the outside employment begins. Thereafter, an employee must provide an update to their supervisor on an annual basis, or sooner if any changes in outside employment occur. Employees who accept outside employment in violation of this policy may be subject to discipline, up to and including termination.

Criminal Arrests and Convictions

Employees must promptly and fully disclose to their supervisor on the next working day:

- All drug- or alcohol-related arrests, citations, convictions, guilty pleas, no contest pleas or diversions that result from conduct which occurred while on duty, on Port property, or in a Port vehicle (see "Substance Abuse and Alcohol" section for more details);
- All arrests, citations, convictions, guilty pleas or no contest pleas that result from crimes involving the theft or misappropriation of property, including money; or
- If an employee is arrested, cited, or convicted of a violation of any law that will prevent them from performing the essential functions of their position.

Reporting an arrest or conviction will not automatically result in termination of employment. Situations will be evaluated on a case-by-case basis.

Employees who are unavailable to report for work because they have been sent to jail or prison may be subject to disciplinary action, including termination.

Americans with Disabilities Act

The Americans with Disabilities Act (ADA), as amended by the ADA Amendments Act of 2008, is a comprehensive federal civil rights law that specifically protects individuals with physical and mental disabilities from discrimination in the workplace.

Individuals are protected under the ADA if any of the following conditions exist:

- They currently have a physical or mental condition that significantly restricts their ability to normally conduct a major life function (e.g., walking, seeing, hearing, breathing, bodily functions, etc.)
- They have a history of such an impairment; or,
- They are regarded as having such an impairment.
- The ADA also prohibits discrimination based on an individual's relationship with someone (e.g., parent, sibling, child, spouse, friend, etc.) with a disability.

The Port will make reasonable efforts to accommodate a qualified applicant or employee with a known disability unless such accommodation creates an undue hardship on the operations of the Port.

Requesting an Accommodation

A reasonable accommodation is any change or adjustment to a job or work environment that does not cause an undue hardship on the department or unit (or, in some cases the Port), and that permits a qualified applicant or employee with a disability to participate in the job application process, to perform the essential functions of a job, or to enjoy benefits and privileges of employment equal to those enjoyed by employees without disabilities. For example, a reasonable accommodation may include providing or modifying equipment or devices, job restructuring, allowing part-time or modified work schedules, reassigning an individual, adjusting or modifying examinations or training materials provided by the Port, providing readers and interpreters, or making the workplace readily accessible to and usable by people with disabilities.

Employees should fill out the Employee Accommodation Request Form¹ as soon as it becomes apparent that reasonable accommodation may be necessary to perform the essential duties of their position. All accommodation requests must be submitted to a supervisor or the Human Resources delegate and should specify which essential functions of the employee's job cannot be performed without reasonable accommodation. In most cases, employees will need to provide medical verification of their need for accommodation. Both the Port and the employee should regularly monitor the accommodation and make adjustments as needed.

Pregnancy Accommodation Policy

The Port is committed to providing reasonable accommodations for employees experiencing limitations due to pregnancy, childbirth, or related medical conditions, as long as such accommodations do not impose an undue hardship on the organization. This policy complies with the federal Pregnant Workers Fairness Act (PWFA) and any applicable state laws and regulations regarding pregnancy-related conditions.

Employees who are concerned that their pregnancy, childbirth, or a related medical condition (including lactation) will impact their ability to work should contact the Human Resources delegate to discuss their options for continuing to work and, if necessary, leave of absence options. The Port will provide one or more reasonable accommodations for employees with known limitations unless such accommodations impose an undue hardship on the Port's operations.

Although this policy refers to "employees," the Port will apply this policy equally to an applicant with known limitations caused by pregnancy, childbirth or a related medical condition.

Requesting a Pregnancy-Related Accommodation

Employees who are concerned that their pregnancy, childbirth or a related medical condition will limit their ability to perform their duties should request an accommodation as soon as it becomes apparent that a reasonable accommodation may be necessary to enable the employee to work. All requests for accommodation should be made with the Human Resources delegate and should specify which essential functions of the employee's job cannot be performed without reasonable accommodation. In most cases, information from the employee's doctor may be needed to assist the Port and the employee in finding an effective accommodation, or to verify

¹ R:\Archives\Administrative Records\Templates & Forms\Human Resources\Employee Accommodation Request Form

the employee's need for an accommodation. Both the Port and employee must monitor the employee's accommodation situation and adjust as needed.

Leave of Absence Options for Pregnant Employees

Employees who are pregnant or experiencing pregnancy-related medical conditions should also be aware of their leave of absence options under Paid Leave Oregon, Oregon's sick leave law, and the Oregon Family Leave Act. See policies in this handbook or speak with the Human Resources delegate.

No Discrimination, No Retaliation

The Port prohibits retaliation or discrimination against any employee who, under this policy: (1) asked for information about or requested accommodations; (2) used accommodations provided by the Port; or (3) needed accommodation.

Employees who ask about, request or use accommodations under this policy and applicable law have the right to refuse an accommodation that is unnecessary for the employee to perform the essential functions of the job or when the employee doesn't have a known limitation.

No-Harassment Policy

The Port prohibits harassment and sexual assault in the workplace or harassment and sexual assault outside of the workplace that violates its employees, volunteers, and interns' right to work in a harassment-free workplace. Specifically, the Port prohibits harassment or conduct related to race, age, religion, color, sex, national origin, physical or mental disability, marital or veteran status, sexual orientation, gender identity, on-the-job injury, genetic information, domestic violence victim status, or any other legally protected characteristic or status recognized under Oregon, federal, or local law.

Each member of management is responsible for creating an atmosphere free of discrimination, harassment, and sexual assault. Further, all employees are responsible for respecting the rights of other employees and to refrain from engaging in conduct prohibited by this policy, regardless of the circumstances, and regardless of whether others participate in the conduct or did not appear to be offended. All employees are encouraged to discuss this policy with their immediate supervisor, any member of the management team, or with the Human Resources delegate, at any time if they have questions relating to the issues of discrimination or harassment.

This policy applies to and prohibits sexual or other forms of harassment that occur during working hours, during Port — related or — sponsored trips (such as conferences or work-related travel), and during non-working hours when that off-duty conduct creates an unlawful hostile work environment for any Port employees. Such harassment is prohibited whether committed by Port employees or by non-employees (including elected officials, members of the community, volunteers, interns and vendors).

Behavior such as telling ethnic jokes; using religious slurs or offensive slang, or other derogatory terms regarding a person's race, sexual orientation, age, sex, national origin, or disability; or mimicking one's speech, accent, or disability are examples of prohibited conduct. Harassing individuals by making derogatory comments regarding protected status or characteristics is strictly prohibited, as well as using any other words or conduct that might create a hostile or offensive work environment.

Sexual Harassment

Sexual harassment includes unwelcome sexual advances, requests for sexual favors, or other verbal or physical conduct of a sexual nature (regardless of whether such conduct is "welcome"), when:

- Submission to the conduct is made either implicitly or explicitly a term or condition of employment.
- Submission to or rejection of the conduct is used as a basis for employment-related decisions; or,
- The conduct has the purpose or effect of interfering with an individual's work performance or creating an intimidating, hostile, or offensive work environment.

Some examples of conduct that could give rise to sexual harassment are unwanted sexual advances; demands for sexual favors in exchange for favorable treatment or continued employment; sexual jokes; flirtations; advances or propositions; verbal abuse of a sexual nature; comments about an individual's body, sexual prowess, or deficiency; talking about your sex life or asking others questions about theirs; leering or whistling; unwelcome touching or assault; sexually suggestive, insulting, or obscene comments or gestures; displays of sexually suggestive objects or pictures; making derogatory remarks about individuals who are gay, lesbian, bisexual or transgender; or discriminatory treatment based on sex. Cell phone use, including text messages and other similar electronic communications, can also be considered harassing behavior. This is not a complete list.

Sexual Assault is defined as unwanted conduct of a sexual nature that is inflicted upon a person or compelled using physical force, manipulation, threat, or intimidation.

Other forms of Prohibited Harassment

The Port also prohibits harassment against an individual based on the individual's race, color, religion, sex, pregnancy, sexual orientation, gender identity, national origin, age, disability, genetic information, veteran status, domestic violence victim status, or any other protected status or activity recognized under Oregon, federal or local law.

The Port also prohibits harassment such as verbal, written or physical conduct that denigrates, makes fun of, or shows hostility towards an individual because of that individual's protected class or protected activity, and can include:

- Jokes, pictures (including drawings), epithets, or slurs.
- Negative stereotyping.
- Displaying racist symbols anywhere on Port property.
- "Teasing" or mimicking the characteristics of someone with a physical or mental impairment or disability.
- Criticizing or making fun of another person's religious beliefs, or "pushing" your religious beliefs on someone who doesn't have them.
- Threatening, intimidating, or hostile acts that relate to a protected class or protected activity; or
- Written or graphic material that speaks badly of or shows hatred toward an individual or group because of one or more protected statuses.
- Negative comments or teasing a person about their natural hair, hair texture, hair type or hair style (see definition of "race" in earlier section). Employees may not touch another employee's hair without permission to do so, even if the touch is extended out of curiosity or as a compliment.

This is not a complete list. All employees are expected to exercise common sense and always demonstrate professional conduct in the workplace.

Workplace Violence

Threats and acts of violence made by an employee against another employee, volunteer, elected official, or member of the public with respect to that person's life, health, well-being, family, or property will be dealt with in a zero-tolerance manner by the Port.

All employees have an obligation to report any incidents that pose a real or potential risk of harm to employees or others associated with the Port, or that threaten the safety, security or financial interests of the Port. Employees are also strongly encouraged to report threats or acts of violence by non-employees, such as vendors or citizens, against any employee, volunteer or elected official. Employees should make such reports directly to their supervisor.

The Port also may conduct an investigation of a current employee where the employee's behavior raises concern about work performance, reliability, honesty, or potentially threatens the safety of coworkers or others.

No-Bullying Policy

The Port strives to promote a positive, professional work environment free of physical or verbal harassment, “bullying,” or discriminatory conduct of any kind. The Port, therefore, prohibits employees from bullying one another or engaging in any conduct that is disrespectful, insubordinate, or that creates a hostile work environment for another employee for any reason. For purposes of this policy, “bullying” refers to repeated, unreasonable actions of individuals (or a group) directed towards an individual or a group of employees, which is intended to intimidate and that creates a risk to the health and safety of the employee(s). Examples of bullying include:

- **Verbal Bullying: Slandering**, ridiculing, or maligning a person or their family; persistent name calling that is hurtful, insulting or humiliating; using a person as butt of jokes; abusive and offensive remarks.
- **Physical Bullying:** Pushing; shoving; kicking; poking; tripping; assault, or threat of physical assault; damage to a person’s work area or property.
- **Gesture Bullying:** Non-verbal threatening gestures, glances that can convey threatening messages.
- **Exclusion Bullying:** Socially or physically excluding or disregarding a person in work-related activities. In some cases, failing to be cooperative and working well with coworkers may be viewed as bullying.
- **Cyber Bullying:** Bullying that takes place using electronic technology, which includes devices and equipment such as cell phones, computers, and tablets as well as communication tools including social media sites, text messages, chat, and websites. Examples of cyberbullying include transmitting or showing mean-spirited text messages, emails, embarrassing pictures, videos or graphics, rumors sent by email or posted on social networking sites, or creating fake profiles on websites for coworkers, managers or supervisors or elected officials.

This is not a complete list.

Employees who have experienced bullying in violation of this policy, who have witnessed an incident of bullying, or who have credible information about an incident, are expected and should bring the matter to the attention of their supervisor, Human Resources delegate or a member of management as soon as possible. If conduct in violation of this policy is found to have occurred, the Port will take prompt, appropriate action, and any employee found to have violated this policy will be subject to disciplinary action, up to and including termination of employment.

Reporting Incidents of Harassment/ Bullying

Employees, volunteers, or interns who have experienced a sexual assault, any harassment, bullying or discrimination in violation of this policy, who have witnessed such behavior, or who have information about such behavior occurring, are expected and should bring the matter to the attention of the Human Resources delegate, Executive Director, any supervisor, or member of management as soon as possible. Employees are strongly encouraged to document the information or incident in any written or electronic form, or with a voice mail message (or phone call). An employee who experiences or witnesses’ harassment or bullying is encouraged, but not required, to tell the harasser that the behavior is offensive and unwanted, and that they want it to stop.

All complaints and reports will be promptly and impartially investigated. While the investigation will be conducted promptly, no specific timeframe can be guaranteed due to the unique nature and varying schedules of each situation. Every effort will be made to complete the investigation within a reasonable time. In all cases, the employee will be notified of the outcome of the investigation, and follow-up checks will be conducted quarterly to ensure the matter has been resolved and continues to meet the Port’s standards.

All complaints of harassment will be investigated promptly and impartially. Discretion will be used during the investigation to maintain as much confidentiality as possible while effectively completing the investigation; however, confidentiality cannot be guaranteed. If an employee is not satisfied with the handling of a complaint or the action taken by management, they should bring the complaint to the next higher level of authority. In all cases, the employee will generally be advised of the outcome.

Any employee or manager found, after appropriate investigation, to have engaged in harassment or to have retaliated against an individual for reporting harassment will be subject to appropriate corrective action, up to and including termination, depending on the circumstances.

External Complaint Procedure

Employees who have been subjected to harassment, sexual assault, or discrimination are encouraged to use the Port's complaint-reporting procedure, described above, to ensure a timely, thorough investigation and handling of the situation.

Employees may, however, seek redress from the Oregon Bureau of Labor and Industries (BOLI) pursuant to ORS 659A.820 to 659A.865, or in a court under any other applicable law, whether criminal or civil. Although the Port cannot provide employees with legal advice, employees should be aware of the statute of limitations applicable to harassment or discrimination claims under ORS 659A.030, 659A.082 or 659A.121 (five years). Further, before an employee can take any legal action against the Port, they must provide written notice of the claim to Port within 180 days of the act or omission the employee claims caused them harm. When an employee can prove harm as a result of unlawful harassment or discrimination in an administrative proceeding or in a court, remedies available to the employee include enforcement of a right, imposition of a penalty, or issuance of an order to the employee's employer (in limited circumstances).

Protection Against Retaliation

The Port prohibits retaliation in any way against an employee because the employee has made a good-faith complaint pursuant to this policy or the law, has reported (in good faith) sexual assault, harassing, bullying or discriminatory conduct, or has participated in an investigation of such conduct.

Employees who believe they have been retaliated against in violation of this policy should immediately report it to the Human Resource delegate, Executive Director, any supervisor, or member of management. Any employee who is found to have retaliated against another employee in violation of this policy will be subject to disciplinary action up to and including termination of employment.

See also the No-Discrimination, No-Retaliation Policy, above, and the Reporting Improper and Unlawful Activity Policy, below.

Support Services After a Harassment Complaint

The Port is committed to supporting employees who have filed harassment complaints. In addition to promptly and thoroughly investigating all complaints, the Port offers various support services to ensure the well-being of the Port's employees:

- Employee Assistance Program (EAP): Full-time employees have access to our EAP, which provides professional counseling services to help cope with the emotional impact of harassment.
- Flexible Work Arrangements: Employees may request flexible working hours or remote work options to feel more comfortable and secure during the investigation process.
- Training and Education: Ongoing training on harassment prevention and response is provided to all employees to create a more informed and supportive workplace culture.
- Reassignment: Temporary or permanent reassignment to a different team or department may be available to help the employee feel safer and more comfortable at work.
- Regular Check-Ins: Regular check-ins with the affected employee are scheduled to provide ongoing support and ensure their needs are being met.
- Restorative Practices: If appropriate and agreed upon by the employee, we implement restorative practices that focus on healing and reconciliation.
- Resource Lists: Employees receive a list of external resources, such as local advocacy groups, legal aid organizations, and crisis hotlines, for additional support.
- Conflict Resolution Services: Mediation or conflict resolution services are available to address any ongoing issues or tensions in the workplace related to the complaint.

By offering these support services, the Port aims to ensure that employees feel heard, supported, and valued throughout and after the harassment complaint process.

Other Employee Rights

Nothing in this policy is intended to diminish or discourage an employee who has experienced workplace harassment or discrimination, or sexual assault, from talking about or disclosing their experience.

The Port is committed to creating and maintaining a workplace free of sexual assault, harassment, discrimination, and retaliation, and it has confidence in the process it has developed for addressing good-faith complaints. However, Oregon law requires the Port to inform employees that if they have been aggrieved by workplace harassment, discrimination or sexual assault and want to enter into an agreement with the Port regarding their experience and/or employment status, the employee should contact the Human Resources delegate. The employee's request to enter into such an agreement must be in writing (email or text is acceptable). Requests of this nature will be considered on a case-by-case basis; such agreements are not appropriate for every situation. If the Port and employee do reach an agreement, the Port will not require an employee to enter into a nondisclosure agreement (which would prohibit the employee from discussing or communicating about their experiences in the workplace or the terms of the agreement) or a non-disparagement agreement (which would prohibit the employee from speaking slightly about the Port or making comments that would lower the Port in rank or reputation). If, however, the employee makes a request for an agreement under this paragraph, nondisclosure and non-disparagement are terms that the Port and the employee may agree to. The employee will have seven days to revoke the agreement after signing it.

Reporting Improper or Unlawful Conduct - No Retaliation

Employees may report concerns about the Port's compliance with any law, regulation or policy, using one of the methods identified in this policy. The Port will not retaliate against employees who disclose information that the employee reasonably believes is evidence of:

- A violation of any federal, Oregon, or local law, rules or regulations by the Port.
- A violation of law, regulation, or standard pertaining to safety and health in the place of employment.
- Mismanagement, gross waste of funds, abuse of authority.
- A substantial and specific danger to public health and safety resulting from actions of the Port or one of its employees; or
- The fact that a recipient of government services is subject to a felony or misdemeanor arrest warrant.

Further, in accordance with Oregon law, the Port will not prohibit an employee from discussing the activities of a public body or a person authorized to act on behalf of a public body with a member of the Legislative Assembly, legislative committee staff acting under the direction of a member of the Legislative Assembly, any member of the elected governing body of a political subdivision, or an elected auditor of a city, county or metropolitan service district.

Employee Reporting Options

Employees who wish to report improper or unlawful conduct should first talk to their supervisor. If the employee is not comfortable speaking with their supervisor, or the employee is not satisfied with their supervisor's response, the employee is encouraged to speak with the Human Resources delegate. Supervisors and managers are required to inform the Human Resources delegate about reports of improper or unlawful conduct they receive from employees.

The Port will not disclose the identity of any employee who reports any of the information described in this policy during an investigation without the written consent of the employee. Reports of unlawful or improper conduct will be kept confidential to the extent allowed by law and consistent with the need to conduct an impartial and efficient investigation.

If the Port were to prohibit, discipline, or threaten to discipline an employee for engaging in an activity described above, the employee may file a complaint with the Oregon Bureau of Labor and Industries or bring a civil action in court to secure all remedies provided for under Oregon law.

Additional Protection for Reporting Employees

Oregon law provides that, in some circumstances, an employee who discloses a good faith and objectively reasonable belief of the Port's violation of law will have an "affirmative defense" to any civil or criminal charges related to the disclosure. For this defense to apply, the employee's disclosure must relate to the conduct of their coworker or supervisor acting within the course and scope of their employment. The disclosure must have been made to: (1) a state or federal regulatory agency; (2) a law enforcement agency; (3) a manager with the Port; or (4) an Oregon-licensed attorney who represents the employee making the report/disclosure. The defense also only applies in situations where the information disclosed was lawfully accessed by the reporting employee.

Policy Against Retaliation

The Port will not retaliate against employees who make reports or disclosures of information of the type described above when the employee reasonably believes they are disclosing information about conduct that is improper or unlawful, and who lawfully accessed information related to the violation (including information that is exempt from disclosure as provided in Oregon law or by Port policy).

In addition, the Port prohibits retaliation against an employee for participating in good faith in any investigation or proceeding resulting from a report made pursuant to this policy. Further, no Port employee will be adversely affected because they refused to carry out a directive that constitutes fraud or is a violation of local, Oregon, federal or other applicable laws and regulations. The Port may take disciplinary action (up to and including termination of employment) against an employee who has engaged in retaliatory conduct in violation of this policy.

This policy is not intended to protect an employee from the consequences of their own misconduct or inadequate performance simply by reporting the misconduct or inadequate performance. Furthermore, an employee is not entitled to protections under this policy if the Port determines that the report was known to be false, or information was disclosed with reckless disregard for its truth or falsity. If such a determination is made, an employee may be subject to discipline up to and including termination of employment.

Political Activity

Employees may engage in political activity except to the extent prohibited by Oregon law when on the job during working hours. This means that employees cannot:

- Be required to give money or services to aid any political committee or any political campaign;
- Solicit money or services (including signatures) to aid or oppose any political committee, nomination or election of a candidate, ballot measure or referendum, or political campaign while on the job during working hours (this is not intended to restrict the right of Port of Hood River's employees to express their personal political views); or
- Be disciplined or rewarded in any manner for either giving or withholding money or services for any political committee or campaign.

DISPUTE RESOLUTION PROCEDURE

The Port recognizes that undisclosed problems can lead to impaired work relationships, dissatisfaction with working conditions, and a decline in operational efficiency. To address this, the Port has established a dispute resolution procedure to solve problems as quickly, fairly, and thoroughly as possible. This procedure provides a method for impartially hearing complaints, resolving problems, and ensuring a fair and objective review. All issues will be handled without prejudice or retaliation. Please note that this procedure does not apply to complaints of discrimination, harassment, or retaliation; employees should use the reporting process outlined in the relevant section of the Handbook for such complaints.

Steps to Resolve Disputes:

1. Initial Discussion with Supervisor:
 - Employees are encouraged to discuss any questions or concerns with their immediate supervisor as soon as they become aware of a problem or have a question.
 - The supervisor will follow up on the concern and work towards resolving the issue.
2. Escalation to Next Level of Management:
 - If the concern involves the immediate supervisor or the employee feels uncomfortable discussing the issue with them, the employee should escalate the matter to the next level of management.
 - This could be the department head or another higher-level manager.
3. Contacting Human Resources:
 - If the issue remains unresolved after discussing with the next level of management, or if the employee prefers, they can bring the concern directly to the Human Resources Delegate.
 - The Human Resources Delegate will review the issue, provide guidance, and work towards a resolution.
4. Formal Written Complaint:
 - For issues that are not resolved through the above steps, employees can submit a formal written complaint to Human Resources.
 - The written complaint should include details of the issue, steps taken to resolve it, and any supporting documentation.
5. Human Resource Review and Investigation:
 - Upon receiving a formal written complaint, the Human Resources Delegate will conduct a thorough and objective investigation.
 - The Human Resources Delegate will gather information, interview relevant parties, and review any documentation related to the issue.
6. Resolution and Feedback:
 - The Human Resources Delegate will provide a written response to the employee outlining the findings of the investigation.
 - The employee will have the opportunity to discuss the resolution and provide feedback.

By following these steps, the Port aims to ensure that all disputes are resolved fairly, promptly, and without any form of retaliation. Employees are encouraged to utilize this procedure to address their concerns and contribute to a positive and productive work environment.

RECRUITMENT PROCESS

The Port's goal is to fill employment vacancies with qualified applicants by recruiting internally, externally, or through both methods. Job applicants will be considered on an equal basis for all positions without regard to sex, age, race, color, religion, national origin, marital or veteran status, sexual orientation, gender identity, genetic information, physical or mental disability, or any other characteristic protected under applicable law, including Veterans' Preference.

The Port seeks talented and motivated professionals to fill all positions at the Port. Whenever a position becomes available and is posted, the hiring manager will ensure that only applicants, both internal and external, who meet the qualifications defined in the Position Description are evaluated. Applicants who meet the minimum qualifications, have a history of strong performance, and are expected to perform at a high level in the position will be further considered.

Current job openings are typically posted on the Port's website, in local newspapers, and other appropriate web listings. The Port's goal is to always select the most qualified person for each available job.

Internal Recruitments

The Port may issue Notices of Internal Recruitment to advertise job openings in-house. Current employees possessing the required knowledge, skills, and abilities to meet the minimum qualification requirements of a position are encouraged to apply.

Employment Applications and Reference Checks

Employment applications received by the Port become the property of the Port and cannot be returned. Misrepresentations, falsifications, or material omissions in any of the information stated in the application may result in the exclusion of the applicant from further consideration for employment or, if the person has already been hired, termination of employment.

It is the Port's policy to check employment references for all applicants being considered for employment. The Port may request a consumer report from an applicant (most commonly for positions within the Finance Department), but only with the applicant's written authorization and upon providing the required disclosure of employee's rights under the Fair Credit Reporting Act. Pursuant to the Fair Credit Reporting Act, if the Port requested and obtained a consumer report from an applicant and decides not to extend an offer of employment, the Human Resources Delegate will provide a copy of the report to the applicant as soon as possible before formally notifying the applicant that an employment offer will not be extended. The formal notification must include notice to the applicant explaining how to contact the reporting agency.

Only the Human Resources Delegate or the Executive Director are authorized to respond to employer reference check inquiries regarding current or former employees. Responses to employment reference checks will be limited to dates of employment, position, title and job location.

Employment of Relatives

The Port prohibits relatives of current employees from holding positions where one directly supervises the other. 'Relatives' include spouses, domestic partners, children, parents, siblings, in-laws, and others related by marriage or domestic partnership. Domestic partners include individuals in dating relationships, and a household member is anyone residing with the employee. This applies regardless of gender, sexual orientation, or genetic relationship.

If a supervisory relationship arises after employment, the supervisor must disclose the relationship to the Human Resources Delegate or the Executive Director.

With respect to a relative relationship, the employees and the Port will jointly attempt to find an alternative work assignment for one of the two employees. If no alternative work assignment is available within ninety (90) days, one of the employees will be required to resign. If neither agrees to resign, the Executive Director will determine which employee will need to be terminated.

With respect to a household relationship, the Human Resources Delegate or the Executive Director will evaluate the situation and determine whether the employees should remain in their positions, or whether an alternative work assignment should be found for one of the two employees. If no alternative work assignment is available within ninety (90) days, the employees may remain in their current positions until an alternative work assignment is available and if the situation does not create unfairness or favoritism or the appearance of unfairness or favoritism.

Failure to disclose relationships or making employment decisions based on them may result in disciplinary action, up to and including termination.

Employment Motor Vehicle Record Checks

Employees working in positions where driving is an essential function of their duties must possess a valid driver's license and must carry auto liability insurance on any personal vehicles used to conduct the Port's business. Employees who use their own vehicles for authorized Port business use should make any necessary arrangements with their insurance carriers.

The Port may verify the validity of an employee's driver's license and/or driving record at the time of hire and at any point during their employment if driving is an essential function of their job or if so, doing relates to a legitimate business purpose of the Port.

While on the Port's business, drivers are expected to make every reasonable effort to operate their vehicle safely, with due regard for potential hazards, weather, and road conditions. Drivers are to obey all traffic laws, posted signs and signals, and requirements applicable to the vehicle being operated. Seatbelts are to be used in all vehicles while on business. Drivers are to ensure that the use of prescribed or over the counter drugs does not interfere with their ability to drive while on business; operating a vehicle under the influence of alcohol or controlled substances is prohibited. Employees are responsible for notifying their manager of any subsequent restrictions, limitations, or other change in their driving status within 72 hours of the change or new restrictions/limitations.

Employees who receive a ticket or citation while driving a Port-owned vehicle or while on the Port's business will be responsible for paying the fine (if any) associated with the ticket or citation and may face discipline up to and including termination.

Introductory Period

New employees are hired on a 180-day introductory period, which serves as an extension of the employee selection process. During this time, employees are considered to be in training and under observation and evaluation by supervisors. The introductory period allows for an assessment of the employee's adjustment to work tasks, conduct, adherence to work rules, attendance, and job responsibilities. This period provides an opportunity for employees to demonstrate satisfactory performance for the position and allows the Port to determine if the employee's abilities align with the position's requirements. It also serves as a chance for the employee to evaluate if the Port meets their expectations as an employer.

At the end of the introductory period, the employee's performance will be evaluated, and a decision regarding their employment status will be communicated in writing. Successful completion of the introductory period results in a transition to regular status. It should be noted that this transition does not alter the at-will nature of the employment and both the employee, and the Port are free to terminate the employment relationship, at any time with or without notice and for any reason not prohibited by law. If an employee's performance is close to satisfactory but falls slightly short, the introductory period may be extended if there is a reasonable expectation that the employee's skills will improve within 30 days. Such an extension requires the supervisor's approval and must be requested before the normal conclusion of the introductory period. If the employee does not meet expectations or if their skills remain unsatisfactory, it is unlikely that their employment will continue.

Promotions and Transfer Training Period

Employees who are promoted or transferred to a new position must also complete a 180-day introductory period. This period is used to determine the suitability of the placement and the employee's ability to satisfactorily perform the required work. If it is determined during this period that the job change is not suitable, the employee will be returned to their original position if a vacancy exists. If no such vacancy is available, the employee will be assigned to any other vacant position deemed suitable by the organization. If no suitable vacancy exists, the employee's employment may be terminated. Should the employee be placed in a position other than their original one, adjustments to pay and benefits may occur.

Re-employment

Employees who resign from the Port in good standing may be eligible for re-employment consideration. Applications received from former employees will be considered and processed using the same procedures and standards that govern all other applicants. Previous performance with the organization will be evaluated if the reference check phase is reached. The Port is not obligated to rehire former employees. If an employee returns within twelve (12) calendar months their previous Sick Leave balance will be restored in full.

Credit for Prior Seniority

Employees who are rehired by the Port will receive credit for prior time worked under the following conditions:

- **Reduction in Workforce:** Employees who were separated due to a reduction in the workforce will receive credit for prior time worked for the purposes of benefit eligibility if they are re-employed within one (1) year after the separation date.
- **Voluntary Resignation:** Employees who voluntarily resigned from their employment with the Port may receive credit for prior time worked for the purposes of benefit eligibility, subject to management approval, if re-employed within six (6) months after the resignation date. A new anniversary date will be established based on the date of rehire.
- **Other Rehires:** All other rehires will be considered new employees, except where the Employee Retirement Income Security Act (ERISA) may dictate otherwise for pension purposes.

This policy ensures that rehired employees receive appropriate credit for their prior service time, aligning with applicable laws and organizational standards.

Employment Classifications

The following terms are used to describe the classification of employees, their employment status and special conditions:

- **Introductory:** Newly hired or promoted employees within the introductory period. The employee can start taking sick time after they have worked for the Port for at least 90 days, unless an agreement with the employee's supervisor or Executive Director is in place prior to taking time off.
- **Training Period Employees:** Newly hired employees who do not fully meet the job's qualifications may be hired at a rate of pay less than the minimum rate of pay for that position's range, not to exceed six months. May be a full-time or part-time employee.
- **Full-time Employees:** Employees whose position is scheduled to work 32-40 hours per week on an ongoing basis (longer than six months).
- **Part-time Employees:** Employees whose position is scheduled to work less than 32 hours per week on average on an ongoing basis (longer than six months). Part-time employees are ineligible for some Port benefits.
- **Limited-Term Employees:** Employees who are hired for an extended but pre-established period (which may be defined by time and/or project). They may work a full-time or part-time schedule of half-time or greater. Full-time Limited-Term Employees are eligible for all Port benefits and holiday pay.
- **Temporary or "Seasonal" Employees:** Employees who are hired for a pre-established period (which may be defined by time and/or project), usually during peak workloads or for vacation relief. They may work a full-time or part-time schedule. Temporary employees are ineligible for Port benefits and holiday pay but are eligible for Oregon paid sick leave and PERS (Public Employee Retirement System) if the PERS eligibility is met.
- **Interns:** Students who are currently enrolled in an accredited school, hired for a limited period of time, usually during the summer. Interns may work a full-time or part-time schedule. Interns are ineligible for Port benefits and holiday pay but are eligible for Oregon paid sick leave. Interns may be paid by the Port or paid by other entities. Unpaid internships must meet specific conditions under both federal and state labor laws.
- **Employment of Minors:** Generally, Port employees must be 18 years of age or older. Occasionally, the Port will hire students or others who are 16 or 17 years old, but the Executive Director must approve their hire in advance. State law defines work hours and conditions.
- **Essential Personnel:** An essential employee is a staff member whose role is critical to the operations and continuity of the organization, particularly during emergency situations or inclement weather (e.g. Facilities staff, some Office Staff, etc.).

Employees are further classified according to federal and state wage and hour laws as exempt or non-exempt, as defined below. Management will make the appropriate designation regarding the status for each new position or when a position changes substantially. If you are uncertain as to your status, ask your supervisor/manager.

- **Exempt Employees:** Employees whose positions meet specific tests established by the Fair Labor Standards Act (FLSA) and state law and who are exempt from overtime pay requirements.
- **Non-exempt Employees:** Employees whose positions do not meet FLSA and state exemption criteria and who are paid a multiple of their regular rate of pay for hours worked in excess of 40 hours per week. Time is managed and recorded in 15-minute increments and rounded appropriately.

EMPLOYMENT RECORD KEEPING

Access to Personnel Files

The Port maintains a personnel record for each employee, with access restricted to authorized persons only. These records contain applications, written evaluations, performance counseling notices, correspondence, and other pertinent employment information. Authorized persons include individuals in a direct line of supervision over the employee to whom the file applies, Human Resources delegate, or any management representative involved in a pending personnel action.

Employees may review their personnel file, except for any references and other material exempt from disclosure under state law, by making advance arrangements with the Human Resources delegate. The Port will provide copies of personnel records or files as required by law, and employees may be asked to reimburse the reasonable cost of providing these copies.

Updating Personnel Records

It is important to keep personnel records current regarding pay, payroll deductions, benefits, and other matters. Employees should notify the Human Resources delegate if there are changes in any of the following information:

- Name
- Marital status
- Address
- Telephone number
- Dependents
- Beneficiary(ies)
- Person to be notified in case of emergency
- Job-related physical or other limitations that impact employment
- Other information having a bearing on employment

An Employee Information Change Form² is available for reporting any changes in personal information.

² File Path: R:\Archives\Administrative Records\Templates & Forms\Human Resources\Employee Information Change Form

EMPLOYEE RELATIONS & ETHICS

ETHICS

The Port believes in treating people with respect and adhering to ethical and fair practices. All Public Officials are held accountable to the states Ethics laws found in ORS 244.

Public Officials

A public official includes anyone serving the State of Oregon or any of its political subdivisions or any other public body in any of the listed capacities, including as an “agent.” An “agent” means any individual performing governmental functions. Governmental functions are services provided on behalf of the government as distinguished from services provided to the government. This may include private contractors and volunteers, depending on the circumstances.

Upon employment with the Port, an individual becomes a Public Official.

Gifts

During a calendar year, a public official, a candidate or a relative or member of the household of the public official or candidate may not solicit or receive, directly or indirectly, any gift or gifts with an aggregate value in excess of \$50 from any single source that could reasonably be known to have a legislative or administrative interest.

During a calendar year, a person who has a legislative or administrative interest may not offer to the public official or a relative or member of the household of the public official any gift or gifts with an aggregate value in excess of \$50.

During a calendar year, a person who has a legislative or administrative interest may not offer to the candidate or a relative or member of the household of the candidate any gift or gifts with an aggregate value in excess of \$50.

Use of Official Position or Office

A public official may not use or attempt to use official position or office to obtain financial gain or avoidance of financial detriment for the public official, a relative or member of the household of the public official, or any business with which the public official or a relative or member of the household of the public official is associated, if the financial gain or avoidance of financial detriment would not otherwise be available but for the public official's holding of the official position or office.

Except:

- Any part of an official compensation package as determined by the public body that the public official serves.
- The receipt by a public official or a relative or member of the household of the public official of an honorarium or any other item allowed under ORS 244.042 (Honoraria).
- Reimbursement of expenses.
- An unsolicited award for professional achievement.
- Gifts that do not exceed the limits specified in ORS 244.025 (Gift limit) received by a public official or a relative or member of the household of the public official from a source that could reasonably be known to have a legislative or administrative interest.
- Gifts received by a public official or a relative or member of the household of the public official from a source that could not reasonably be known to have a legislative or administrative interest.
- The receipt by a public official or a relative or member of the household of the public official of any item, regardless of value, that is expressly excluded from the definition of “gift” in ORS 244.020 (Definitions).

- Contributions made to a legal expense trust fund established under ORS 244.209 (Application to establish fund) for the benefit of the public official.

A public official may not solicit or receive, either directly or indirectly, and a person may not offer or give to any public official any pledge or promise of future employment, based on any understanding that the vote, official action or judgment of the public official would be influenced by the pledge or promise.

A public official may not attempt to further or further the personal gain of the public official through the use of confidential information gained in the course of or by reason of holding position as a public official or activities of the public official.

A person who has ceased to be a public official may not attempt to further or further the personal gain of any person through the use of confidential information gained in the course of or by reason of holding position as a public official or the activities of the person as a public official.

A person may not attempt to represent or represent a client for a fee before the governing body of a public body of which the person is a member. This subsection does not apply to the person's employer, business partner or other associate.

The provisions of this section apply regardless of whether actual conflicts of interest or potential conflicts of interest are announced or disclosed under ORS 244.120

Honoraria

A public official may not solicit or receive, whether directly or indirectly, honoraria for the public official or any member of the household of the public official if the honoraria are solicited or received in connection with the official duties of the public official. A public official may receive of an honorarium or a certificate, plaque, commemorative token or other item with a value of \$50 or less; or receive an honorarium for services performed in relation to the private profession, occupation, avocation or expertise of the public official or candidate.

Financial Interest in Public Contracts

A former public official cannot have a financial interest in a public contract for two years post-authorization. Employees must report potential conflicts. If a retired public official is considered for consultancy, internal review by legal counsel is required to ensure compliance. Non-compliance may lead to disciplinary action, including separation.

CONFIDENTIALITY

Organization and Customers

At the Port, employees have access to highly confidential and proprietary information, including information about the Port's business plans and customers. Customers trust the Port with confidential information and disclosing this information without authorization would have a materially adverse impact on the Port's integrity and on its relationships with the customers. Employees must not disclose any information pertaining to the organization or its customers without prior explicit approval of their managers/supervisors and must sign a Release of Confidential Information form³.

No Port records or information, including documents, files, records, computer files, and similar materials may be removed from the Port's premises without permission from the Port, except in the ordinary course of performing duties on behalf of the Port. Additionally, the contents of Port records or information otherwise obtained in regard to business may not be disclosed to anyone except where required for a business purpose. This

³ R:\Archives\Administrative Records\Templates & Forms\Human Resources\Release of Confidential Information

prohibition also applies to items posted in a blog or website. Employees are subject to appropriate corrective action, up to and including termination, for revealing confidential information.

Employee Records

The Port's philosophy is to safeguard personal employee information in its possession to ensure the confidentiality of this information. Additionally, the Port will only collect personal information that is required to pursue its business operations and to comply with government reporting and disclosure requirements. Personal information collected by the Port includes employee names, addresses, telephone numbers, e-mail addresses, emergency contact information, EEO data, social security numbers, date of birth, employment eligibility data, benefit plan enrollment information, which may include dependents' personal information, and school/college or certification credentials. All pre-employment inquiries, including reference check records, as well as former employee files are maintained in locked, separate areas and are not used by the Port in the course of business operations.

Personal employee information will be considered confidential and, as such, will be shared only as required and with those who have a need for access to such information. All hard copy records will be maintained in locked, secured areas with access limited to those who have a need for such access. Personal employee information used in business system applications will be protected under company proprietary electronic transmission and Virtual Private Network policies and security systems. Participants in company benefit plans should be aware that personal information will be shared with plan providers as required for claim handling or record keeping needs. Port-assigned information, which may include organizational charts, department titles and staff charts, job descriptions, department budgets, company coding and recording systems, telephone directories, e-mail lists, and company facility or location information and addresses, is considered by the company to be proprietary company information to be used for internal purposes only. The Port retains the right to communicate and distribute such information as it feels necessary to conduct business operations.

If an employee becomes aware of a breach in maintaining the confidentiality of any personal information, the employee should report the incident to the Human Resources delegate. The Human Resources delegate has the responsibility to investigate the incident and take or recommend corrective action. Please understand that the reasonableness of actions taken in these circumstances will be taken into consideration. Examples of the release of personal employee information that will not be considered a breach include the following:

- Release of partial employee birth dates [i.e., day and month, which is not considered confidential and will be shared with supervisors/managers who elect to recognize employees on such dates].
- Personal telephone numbers or e-mail addresses may be distributed to supervisors/managers in order to facilitate company work schedules or business operations.
- Employee identifier information used in salary or budget planning, review processes, and for timekeeping purposes will be shared with supervisors/managers.
- Employees' company anniversary dates will be distributed to appropriate supervisors/managers periodically.
- Employee and dependent information may be distributed in accordance with open enrollment processes, for periodic benefit plan changes, or for benefit statement updates.

Should a security breach occur, employees will be notified electronically or in writing as soon as possible.

WORKPLACE RULES

Workplace Professionalism

The Port has established policies and procedures to ensure orderly operations and the fair treatment of employees. These include:

- **Workplace Respect:** Employees must care for and properly maintain Port records, equipment, and property. Each employee is responsible for the appropriate use and accuracy of items in their custody.
- **Compliance:** Employees are required to follow all applicable codes, laws, regulations, and Port policies.
- **Professional Conduct:** Professionalism and respect toward customers, vendors, business associates, and coworkers are mandatory. Behavior such as abusive language, harassment, bullying, or conducting personal business during work hours will not be tolerated. This includes responsible behavior regarding alcohol consumption when representing the Port.
- **Confidentiality:** Confidential information, including personnel data and trade secrets, must be protected.
- **Dress Code:** Employees should dress neatly and professionally to promote safety and create a positive impression on customers, visitors, and coworkers.

Non-compliance with these policies may result in corrective action, up to and including termination.

Workplace Professionalism and Unprofessional Conduct

The Port prohibits any form of unprofessional behavior, which includes incivility, harassment, or interference with others' work. Employees must work cooperatively, focusing on customer service and productivity. Unprofessionalism, whether exhibited on-site or off-site, undermines these values and will not be tolerated. Corrective action will be taken for any violations.

Unprofessional Behavior Examples (not exhaustive):

- Public humiliation in any form.
- Interference with someone's job performance, including assigning unrelated tasks.
- Taking credit for another person's ideas.

Any employee experiencing unprofessional behavior should report it following the process outlined in the no-harassment policy. False or malicious complaints will also be subject to corrective action.

Attendance, Punctuality and Reporting Absences

Employees are expected to report to work as scheduled, on time and prepared to start work. Employees are also expected to remain at work their entire work schedule, except for unpaid break periods or when required to leave on authorized Port business, and perform the work assigned to or requested of them. Late arrivals, early departures, or other absences from scheduled hours are disruptive and must be avoided.

Unless specified otherwise, employees who will be unexpectedly absent from work for any reason or who will not show up for work on time must inform their supervisor via phone call, text or email no later than two hours before the start of the employee's shift/workday. Not reporting to work and not calling to report the absence is a no-call/no-show and is a serious matter. The first instance of a no call/no show will result in a final written warning. The second separate offense may result in termination of employment with no additional disciplinary steps. A no call/no show lasting three days may be considered job abandonment and may result in termination of employment.

Off-Duty Conduct

Generally, the Port regards employees' off-duty activities as personal matters. However, off-duty conduct that negatively impacts the Port's reputation or the employee's ability to perform their job may result in corrective action, including termination. This includes criminal acts or behavior that adversely affects the Port.

Open Door Policy

The Port values open, honest communication. Employees are encouraged to raise issues, complaints, suggestions, or questions with their immediate supervisor first. If the response is unsatisfactory or if the issue involves the supervisor, employees should next reach out to the department director. If still unresolved, the matter can be escalated to the Human Resources delegate or the Executive Director.

Interpersonal Communications

Every employee is entitled to be treated with professionalism and respect by coworkers. Communication between employees must be courteous, respectful, and professional. The manner and tone of communication are important.

Workspace Bulletin Boards & Announcements

The Port has bulletin boards in the employee food prep room, the Maintenance Shop, and the Toll Booth to communicate important information. Items to be posted must be approved in advance by the Executive Director or Human Resources delegate. Employees are responsible for regularly reviewing the information posted on the bulletin boards in their work areas.

Subpoena and Deposition Response Procedure

Due to the various aspects of the Port's operations and the nature in which it performs its responsibilities, litigation involving the Port or requiring Port staff to be a witness is rare. In most situations, the involvement of Port personnel is limited to providing and identifying Port records in a lawsuit not involving the Port. If an employee receives a subpoena for a deposition or court appearance, they must follow these steps:

- Notify Port management upon receiving the subpoena.
- Provide a copy of the subpoena to the Executive Director.
- The Executive Director will consult with Port legal counsel for advice and direction.

Port legal counsel will guide the appropriate course of action and, if necessary, accompany the employee to the deposition or trial.

Charitable Activities and Solicitation

The Port encourages employee participation in charitable organizations of their choice, but participation in these activities is entirely voluntary. Employees should feel no pressure to participate, and non-participation will not be viewed negatively. Using Port facilities and resources for charitable purposes must be handled carefully. The Port supports small-scale efforts, such as selling raffle tickets or candy for a child's school or youth group, as long as these activities do not disrupt the work environment and are conducted during breaks or meal periods. Employees must ensure that no one feels obligated to participate. All charitable activities must be approved by the Port, and employees should contact their supervisor for specific details. The Port also encourages employees to volunteer in the community as a positive representation of the organization, but such involvement is always at the employee's discretion.

Children in the Workplace

The Port supports the national "Bring Your Child to Work Day" event for school-age children, observed on the fourth Thursday in April each year. To maintain a professional business environment and ensure productivity, participation in this event requires prior approval from the employee's supervisor. Participating employees are responsible for their children and must accompany them in the workplace throughout the day. School-age children may participate during the employee's regularly scheduled workday.

Pets in the Workplace

Employees may bring pets to the workplace on an occasional basis, provided the pets do not disrupt the work environment. Employees are fully responsible for their pets and must accompany them at all times while they are on Port premises.

Whistleblower Protection

The Port encourages any employee with knowledge of an illegal or dishonest activity to report it to the Executive Director. All such issues will be promptly investigated with the intent to determine fault and institute any appropriate corrective measures. Examples of illegal or dishonest activities are violations of federal, state, or local laws; billing for services not performed or for goods not delivered; and other fraudulent financial reporting. Any employee wishing for more information can obtain further details from the Human Resource delegate.

If an employee has knowledge of or a concern of illegal or dishonest fraudulent activity, the employee should immediately contact a direct supervisor/manager, Human Resource delegate, or the Executive Director. The employee must exercise sound judgment to avoid baseless allegations. An employee who intentionally files a false report of wrongdoing will be subject to corrective action, up to and including termination.

Whistleblower protections are provided to maintain confidentiality and to prevent retaliation. Although someone's identity may have to be disclosed to conduct a thorough investigation, to comply with the law, and to provide accused individuals their due course, the privacy of the individual making the report will be protected to the extent possible. The Port will not retaliate against a whistleblower. This includes, but is not limited to, protection from retaliation in the form of an adverse employment action such as termination, compensation decreases, or poor work assignments as well as threats of physical harm. Any whistleblower who believes retaliation has occurred must contact the Executive Director immediately. The right of a whistleblower to protection against retaliation does not include immunity for any personal wrongdoing that is alleged and investigated.

All reports of illegal and dishonest activities will be promptly submitted to the Executive Director who is responsible for investigating and coordinating corrective action.

PROFESSIONAL APPEARANCE AND DRESS CODE POLICY

Employees play a crucial role in shaping the atmosphere and reputation of the Port. The way employees present themselves significantly influences the impression made on customers and clients. A professional appearance is essential for fostering a positive perception and instilling confidence.

Commitment to Respect and Individuality

The Port is committed to creating a workplace where all individuals feel respected and valued. The Port recognizes the significance of personal expression, including natural hair textures and hairstyles, as important reflections of identity and culture. Any form of discrimination based on these attributes is not tolerated.

Professional Appearance Standards

Managers have the discretion to determine the appropriateness of an employee's appearance. Employees who do not meet professional standards may be sent home to change and will not be compensated for that time off. Essential elements of appropriate dress include clothing that is neat, clean, and well-maintained. The following guidelines must be observed:

- Overly revealing clothing, tank tops, halter tops, and any extremes in dress, accessories, fragrance, or hairstyles are not permitted.
- Clothing, jewelry, and hairstyles should not pose any safety hazards.
- Body piercing jewelry and body art that do not convey a professional image should be covered.
- Management may grant exceptions to the dress code for special occasions.

Business Casual Dress Code

Business casual attire is permitted, except during periods when business casual days are suspended, and business dress is required. A more relaxed business casual dress code is allowed on Fridays, provided job duties do not necessitate more formal wear. Regardless of the day, clothing must always be neat, clean, and in good repair. Business dress is mandatory when meeting clients. The dress code policies may be updated to reflect changes in business fashion trends and/or weather.

Department-Specific Guidelines: Uniforms and Port Logo Clothing

Certain departments may have specific dress guidelines. Employees needing to change clothes for meetings during work hours must use personal or vacation time. Employees provided with uniforms by the Port must wear

them every workday, including after-hours, holiday, and weekend call-outs. Proper footwear provided by the Port is also required. Annually, the Port will provide a limited amount of Port logo clothing to all employees. This clothing supports the professional and customer service-oriented culture of the organization. Port logo clothing may be worn at work, in compliance with the Port's dress code, and outside of work to promote community awareness.

This policy ensures that all employees present themselves professionally, enhancing the Port's image and fostering a respectful and inclusive workplace. Adherence to these guidelines is essential for maintaining a professional environment that benefits both employees and the community.

COMMUNICATIONS AND SOFTWARE SYSTEMS POLICY

Electronic Communications Systems

The Port provides electronic communication systems to ensure efficient and effective communication within the organization and with external clients and vendors. Employees are encouraged to familiarize themselves with these tools and their proper usage. This policy outlines the guidelines for accessing and disclosing information when using these systems. All users, including employees and external parties, are expected to adhere to this policy.

The Port's electronic communication systems include, but are not limited to, computers, software, email, copiers, fax machines, telephones, cell phones, voicemail, messengers, and various online services. These systems are to be used primarily for business purposes during business hours. Any personal use should be minimal and must not interfere with business operations.

These systems are not private or confidential. The Port reserves the right to review, audit, intercept, access, and search these systems at any time, and to disclose contents as needed, within the bounds of current and future laws. All messages and data sent through these systems remain the property of the Port.

Employees must not allow proprietary or confidential information to enter the public domain through electronic transmissions. Examples of such information are outlined in the Confidentiality Policy. These systems must not be used to receive or distribute copyrighted materials, trade secrets, or other proprietary information without prior authorization.

All communications via these systems are subject to the Port's anti-harassment, anti-discrimination, and non-solicitation policies. Employees are expected to carefully review the wording, tone, and content of their communications before sending them.

Questions regarding the proper use of communication or software systems should be directed to a supervisor. Violations of this policy should be reported immediately. Improper use or policy violations may result in disciplinary action, up to and including termination.

Email System

Employees are reminded to be courteous and professional when using the email system. Emails should be written with the same care as letters or internal memos. Even deleted emails can be retrieved, and while the Port reserves the right to access any email, it expects employees to respect others' privacy and not access emails not intended for them. Employees should not use the email system for personal communications and should always consider the possibility of misdirection or forwarding.

Software and Hardware Use

Employees should not expect privacy for any files, including personal files on Port systems. All files on Port systems are subject to review by Port staff. The following policies apply:

- Port licenses software and does not own it; unauthorized copying is prohibited.
- Use software only per license agreements.
- Do not download or upload unauthorized software.
- Report misuse of software to the Finance Director or Executive Director.
- Illegal software reproduction can lead to civil damages, criminal penalties, and disciplinary action, including termination.
- Do not destroy, modify, or abuse hardware or software.
- Do not develop or distribute malicious software.

Questions about software use should be directed to the Finance Director or IT consultant.

Unauthorized Access

Employees are not permitted unauthorized access to electronic communications of other employees or third parties unless directed to do so by Port management. No employee can examine, change or use another person's files, output, username or password unless they have explicit authorization from management to do so.

Laptop Security

Staff issued laptops and related equipment must follow Port security guidelines. Employees should always follow organization guidelines in safeguarding equipment. Refer to the Telework or Telecommute section in this handbook for more details.

Mobile Devices

Employees must protect confidential information accessed via mobile devices. The Port reserves the right to delete data and applications from devices containing Port information to protect confidentiality. This policy covers devices like smartphones, tablets, and laptops. Lost or stolen devices must be reported immediately to the Human Resources delegate or IT consultant. Mobile devices should be set to lock after every 10 minutes for security reasons, and a PIN-based lockout is required. The PIN must be provided to the Human Resources delegate or IT consultant.

Internet Use

Internet access via Port resources is intended to facilitate effective use of employee time and effort. This use cannot disrupt or interfere with the work of other network users, adversely affect the operation of the Internet or the Port's internal network or misrepresent the interests of the Port. All use of the Internet must comply with applicable laws and policies, including those related to sexual harassment and illegal activities.

The safety and security of the Port's network and resources must be considered when using the Internet. Users should be cautious and skeptical when downloading resources from the Internet.

Employees have no right to expect that Internet access is private. The Port reserves the right to monitor and record all accesses to any website or newsgroup from any Port computer at any time and to use this information in disciplinary actions or legal proceedings. Internet records are public records and are subject to the same rules for public inspection and retention as all other Port records.

Internet use should support education and research consistent with the employee's position. Users must:

- Maintain the integrity of files and data.
- Treat information created by others as private property.
- Use the network without disrupting others.
- Avoid accessing or processing inappropriate material.
- Refrain from using the Internet for commercial purposes.

Unauthorized Internet activity may result in the discontinuation of access privileges and disciplinary action.

Social Media Policy

For purposes of this policy, "social media" includes all means of communicating or posting information or content of any sort on the Internet, including on personal or third-party blogs, journals, diaries, personal or commercial websites, social networking websites, web bulletin boards, or chat rooms, whether or not associated or affiliated with the Port, as well as any other form of electronic communication.

Employees are ultimately responsible for what they post online. Before creating online content, it is essential to consider the risks and rewards involved. Any conduct that adversely affects job performance, the performance of coworkers, or negatively impacts the Port's residents, those working on behalf of the Port, or the Port's legitimate business interests may result in disciplinary action, up to and including termination.

Prohibited Postings

Employees will be subject to discipline, up to and including termination, if they create and post any text, images, or other media that violate Port policies, including its no-harassment, no-discrimination, and workplace violence policies. Similarly, postings that include threats of violence, or are physically threatening, intimidating, bullying, or harassing, will not be tolerated and may subject an employee to disciplinary action, up to and including termination.

Employees must not create a link from their blog, website, or other social networking site to a Port-owned or maintained website without identifying themselves as a Port employee.

Employees should express only their personal opinions and must not represent themselves as spokespersons for the Port unless authorized by their manager or supervisor to do so. If the Port is a subject of the content being created, employees must be transparent about their employment with the Port and clarify that their views do not represent those of the Port, its employees, or its elected officials.

Encouraged Conduct

Employees are expected to be fair and courteous to coworkers, residents, Port employees and elected officials, as well as suppliers and third parties doing business with the Port.

It is generally more effective to resolve work-related complaints by speaking directly with coworkers or utilizing the Port's Open-Door Policy rather than posting complaints on social media. If employees choose to post complaints or criticism, they should avoid making statements, posting photographs, videos, or audio that could reasonably be viewed as malicious, obscene, threatening, intimidating, or disparaging to citizens, coworkers, Port employees, or elected officials, or that might constitute harassment or bullying, or violate Port policies. Examples of prohibited conduct include offensive posts intended to harm an individual's personal or professional reputation or posts that could contribute to a hostile work environment based on race, sex, disability, religion, or any other status protected by law or Port policy.

Employees must maintain the confidentiality of the Port's confidential information. This includes refraining from posting internal reports, policies, procedures, or other internal, Port-related confidential communications or information.

Nothing in this policy is meant to prevent employees from exercising their right to make complaints of discrimination or workplace misconduct, engage in lawful collective bargaining activity, or express an opinion on matters of public concern, provided such expression does not unduly disrupt Port operations. Employees are free to express themselves as private citizens on social media sites; however, their expression must be balanced against the Port's interest in fulfilling its public responsibilities effectively and efficiently.

Request for Employee Social Media Passwords

Supervisors and managers at the Port are prohibited by law from requiring or requesting an employee or applicant to disclose or provide access through the employee's or applicant's username, password, or other means of authentication that provides access to personal social media accounts. This includes usernames and passwords that would otherwise allow a supervisor or manager to access private email accounts not provided by the Port.

Nothing in this policy prohibits the Port from requiring an employee to produce content from their social media or internet account in connection with a Port-sponsored investigation into potential misconduct, unlawful or

unethical behavior, or policy or rule violations. Refer to the Communications Plan⁴ for Social Media staff guidelines.

Voice Mail System

The voice mail system is for business use only. The Port reserves the right to monitor and access all voice mail messages. Employees are not authorized to retrieve or listen to voice mail messages not intended for them without prior approval, except in case of an emergency.

Telephone Usage, Cell Phones and Mobile Devices in General

Personal cell phone use should be limited to designated break and lunch periods. The use of cell phones while driving Port vehicles or operating equipment is strictly prohibited and may result in disciplinary action. For further details, please refer to the "Driving While on Business" section above.

Employees are permitted to bring personal mobile devices to work. However, during working hours, the use of such devices should be limited to emergencies, meal periods, or rest breaks.

Employees using personal or Port-provided mobile devices must comply with the Port's policies against harassment, bullying, and discrimination. Any violation of these policies, including inappropriate texts, instant messages, or DMs sent to other employees or non-employees, may result in disciplinary action, up to and including termination.

Non-exempt employees are not permitted to use personal or Port-provided mobile devices for work-related purposes outside of their regular work schedule without prior written authorization from their supervisor. This includes, but is not limited to, reviewing, sending, or responding to emails or text messages, and making or responding to calls. Violating this policy may lead to disciplinary action, up to and including termination. Non-exempt employees are still responsible for accurately recording all hours worked.

Employee Use of Port - Provided or Paid for Mobile Devices

Mobile devices are made available to Port employees on a limited basis to conduct Port's business. Determinations as to which employees receive Port-provided mobile devices will be made on a case-by-case basis; employees are not guaranteed a cell phone or cellular device. In certain cases, the Port may provide a monthly cellular telephone allowance to employees who regularly make work-related calls away from the office using their personal cell phones. For more information, employees should contact the Human Resources delegate.

Employees who receive a mobile device from Port must agree to not use the mobile device for personal use except in emergency situations and must abide by all aspects of the Mobile Device Policy. Further, employees who receive a cell phone or mobile device from Port must acknowledge and understand that because the mobile device is paid for and provided by Port, or subsidized by Port, any communications (including text messages) received by or sent from the mobile device may be subject to inspection and review if Port has reasonable grounds to believe that the employee's use of the cell phone violates any aspect of the Mobile Device Policy or any other Port policy. Employees should have no reasonable expectation of privacy in a Port-provided or -paid for mobile device. An employee who refuses to provide Port access to their personal mobile device in connection with an investigation and after reasonable notice may be subject to discipline, up to and including termination.

Family and friends may not use an employee's Port-provided mobile device.

Mobile Devices and Public Records

Port-related business conducted on Port-provided or personal cell phones/cellular devices may be subject to disclosure and production under Oregon's Public Records laws or in connection with litigation filed against Port or individual employees.

⁴ R:\Archives\Policy Documents\Policies & Procedures\Administrative\Communications Plan

Use of Generative Artificial Intelligence (AI) Systems

Generative Artificial Intelligence (AI) systems have rapidly gained popularity and widespread adoption, presenting significant opportunities for the Port to enhance efficiency, reduce errors, and better serve the community. However, these technologies also introduce potential impacts and risks that require careful consideration.

Guidelines when using AI:

- **Confidentiality and Privacy:**
 - Do not input sensitive, confidential, regulated data, or personally identifiable information of the public into generative AI systems.
 - When unsure about data sensitivity, consult your supervisor.
- **Content Review and Fact-Checking:**
 - Verify and fact-check content and outputs generated by AI tools.
 - Employees are accountable for ensuring accuracy and appropriateness of AI-generated outputs.
- **Bias and Fairness:**
 - Be vigilant for potential biases inherent in AI systems, reflecting cultural, economic, and social biases from source materials.
 - Review AI-generated content to mitigate unintended biases or potentially harmful materials.

Technology Use Requirements:

Port email addresses must be used when setting up accounts for AI tools, adhering to Port technology policies.

IT Evaluation for AI Tools:

Before purchasing any technology, including AI tools, employees must submit an IT Help ticket for evaluation.

IT will assess whether existing solutions can be utilized, ensure security compliance, and evaluate ongoing maintenance and vendor stability.

Public Records

Information generated or exchanged for government work is subject to Public Records laws regardless of the media or device used. The Port is required to maintain these records.

This policy ensures the proper use of communication and software systems, protecting the Port's interests and maintaining a professional and efficient workplace. Adherence to these guidelines is mandatory and crucial for all employees. Violations of this policy may result in corrective action, up to and including termination. Employees should not delete or destroy any records they have created that pertain to Port business. If employees have any questions regarding this policy, they are encouraged to consult with their supervisor or the Human Resources delegate for further clarification.

PERFORMANCE MANAGEMENT AND REVIEW POLICY

The Port values the contributions of all employees and is committed to ensuring a meaningful performance evaluation system. Periodic performance evaluations are conducted, with the goal of doing so annually, to monitor the effectiveness of the Port's operations and to support each employee in maximizing their potential and contribution to the organization.

Objectives of the Annual Performance Review Process

The primary goals of the annual performance review process are:

- To inform employees about their performance relative to established standards.

- To assess how well managers and supervisors support employees in achieving work performance objectives.
- To ensure open communication and dialogue.
- To provide a consistent, objective, and fair method for making compensation decisions.
- To identify areas where employees may need additional training.
- To serve as a tool for career planning.
- To document employee performance and contributions.

Responsibilities of Managers

Managers are responsible for facilitating professional development opportunities and actions designed to improve and enhance employee performance. This includes:

- Providing reasonable training, including computer software proficiency.
- Assigning, directing, controlling, and reviewing employee work.
- Assisting employees in identifying and correcting performance deficiencies.
- Objectively evaluating employee performance during the evaluation period.
- Implementing Performance Improvement Plans (PIPs) for employees who do not meet performance expectations.

Employee Participation

The performance evaluation process is participatory, involving verbal and/or written input from both employees and managers. This collaborative approach ensures that employees are best positioned to contribute to the improvement of the Port. Employees are encouraged to:

- Inquire about their performance periodically.
- Accept new responsibilities and show initiative.
- Review opportunities for advancement within the Port.
- Seek assistance in developing a goal-oriented path for career advancement.
- Explore available training opportunities to enhance their skills.
- Provide feedback to their supervisors to improve the evaluation process.

Evaluation Schedule

Performance evaluations are conducted at the completion of six months of service, at twelve months of service, and periodically thereafter with the goal of conducting them annually. These evaluations serve as a basis for decisions related to training, job assignments, merit-based pay increases, professional development, promotions, and retention.

Evaluation Tools and Documentation

The Port utilizes the Employee Performance Evaluation Form⁵, or a form that closely follows the noted form to track and document goals, performance, and achievements throughout the year. The form, along with any employee comments and response materials, are included in the personnel files. The Port ensures the strict confidentiality of employees' performance evaluations. Upon completion of the performance review process, the completed forms are submitted to the Executive Director or designee for approval.

Evaluation Outcomes

At the end of the evaluation, there should be:

- A solid understanding of the past year's performance, including any differences in performance factor rating and overall rating.
- Clear direction for the upcoming period.
- An understanding of any changes in compensation, if applicable.
- The beginning of the development of next year's goals.

⁵ R:\Archives\Administrative Records\Templates & Forms\Human Resources\Evaluation & Performance Review Forms

- A signed annual review by both the employee and the supervisor.

Continuous Feedback and Improvement

The Port emphasizes the importance of continuous feedback throughout the year. Managers and employees should engage in regular discussions to address performance issues promptly and keep employees aligned with their goals.

Recognition and Rewards

Outstanding performance should be recognized and rewarded to encourage and motivate employees. Details are included in the Merit-Based Step System in this handbook. (Section: Additional Compensation: Other Benefits)

Conflict Resolution

Employees have the right to appeal or discuss disagreements with their performance evaluations. This ensures fairness and transparency in the evaluation process.

Training for Evaluators

Managers and supervisors will receive training in conducting effective and unbiased performance evaluations to ensure consistency and fairness across the organization.

Use of Technology

The Port may use specific tools or software to manage the performance review process, ensuring consistency, efficiency, and ease of use.

Alignment with Organizational Goals

Performance evaluations are aligned with the Port's strategic objectives and values, reinforcing how individual performance contributes to the broader mission of the organization.

This policy aims to foster a supportive and effective performance management system that benefits both employees and the Port. Adherence to these guidelines ensures a fair, transparent, and productive evaluation process that drives continuous improvement and professional growth. Violations of this policy may result in corrective action, up to and including termination.

CORRECTIVE ACTION

Groups of people working together for any purpose require certain guidelines regarding their conduct and relationships. Accordingly, employees must be aware of their responsibilities to the Port and their coworkers. The Port strives to take a constructive approach to corrective action matters to ensure that actions which interfere with operations or an employee's job are addressed.

The Port generally follows these corrective action steps: (1) oral reprimand; (2) written reprimand; (3) suspension without pay; and (4) discharge. However, where warranted by the nature of the offense or particular circumstances, the Port may, at its discretion, initiate discipline at an advanced step in the corrective action process or implement other disciplinary measures (e.g., demotion, coaching) as deemed appropriate. Counseling and special evaluations may also be part of the discipline process, as determined by the Port at its sole discretion.

The Port retains the right to consider the circumstances of the event and the employee's performance and work history when determining what action to take. The Port may, at its discretion, deviate from the established guidelines as it deems necessary under the circumstances. In all matters of corrective action, the Port reserves complete discretion, except as limited by law. In all disputes, investigations, or controversies, the Port's determination of the facts, made in good faith, will be conclusive. The Port reserves the right to interpret these policies as situations arise, and its interpretation, made in good faith, shall be final.

Violations of the Port's standards will result in corrective action, up to and including termination. In deciding on the appropriate corrective action, the Port will consider relevant factors, including the seriousness of the infraction, the employee's past record, and other surrounding circumstances.

Although it is impossible to identify every potential violation of standards of conduct, the following is a partial list of infractions that may result in disciplinary action, including but not limited to:

- Falsifying employment applications, timecards, personnel records, or other Port documents
- Unauthorized use, removal, or destruction of Port or employee property
- Gambling, carrying weapons or explosives, or violating criminal laws on Port premises
- Sexual harassment or harassment based on an employee's membership in a protected class
- Fighting, throwing objects, horseplay, practical jokes, or disorderly conduct
- Engaging in fraud or sabotage
- Threatening, intimidating, coercing, using abusive language, or interfering with others' performance, or causing substantial workplace disruptions
- Excessive absenteeism or tardiness
- Violating the drug and alcohol policy, including possession, sale, or use of intoxicants or illegal drugs on Port premises, in Port vehicles, or while on Port business
- Insubordination, refusal to comply with legitimate instructions, or failure to perform reasonable assigned duties
- Violating safety, health, or security rules, or failing to follow related procedures
- Damaging or destroying Port property, either carelessly or intentionally
- Performance that, in the Port's opinion, does not meet the job requirements
- Engaging in other practices that the Port deems inconsistent with reasonable rules of conduct necessary for the welfare of the Port, its employees, or customers
- Violating the Port's communication standards
- Inability or unwillingness to cooperate with coworkers
- Failing to safeguard Port assets
- Failing to notify a supervisor when unable to report to work or when leaving work during normal hours without permission
- Failing to observe work schedules, including rest breaks and meal periods
- Sleeping on the job or feigning illness or injury to avoid working
- Failing to attend scheduled training sessions or related activities, such as conferences or workshops, paid for by the Port
- Excessive personal phone calls or texting during work hours
- Violating any Port rule, policy, or practice, whether written or unwritten

This list is representative of actions that may result in disciplinary measures. It is not comprehensive and does not alter the employment-at-will relationship between the employee and the Port. If employees have questions regarding the application or intent of these policies, they should consult their supervisors. Adherence to the Port's work standards will help ensure corrective action is unnecessary.

COMPENSATION

PAY EQUITY

The Port is dedicated to ensuring that all employees receive an equitable total compensation package, which is determined by a variety of factors pertinent to their position, job performance, education, and experience. The Port's commitment to pay equity reflects its broader dedication to fairness, transparency, and the recognition of individual contributions within its workforce. Further, the Port supports Oregon's Pay Equity Law and federal and Oregon laws prohibiting discrimination between employees on the basis of a protected class (as defined under Oregon or federal law) in the payment of wages or other compensation for work of a comparable character.

The Port values open communication and encourages any employee who believes they are not being compensated fairly to address their concerns proactively. Employees should feel comfortable discussing their compensation queries with their immediate supervisor or the Human Resources delegate. These discussions are intended to provide clarification and, where necessary, to review and adjust compensation in accordance with the established policies and criteria.

The Port believes that maintaining pay equity is essential for fostering a motivated and productive workforce, and the Port is committed to regular reviews of its compensation practices to ensure ongoing fairness and alignment with industry standards.

PAY PRACTICES

In addition to its commitment to pay equity, the Port has established comprehensive pay practices to ensure a fair and competitive compensation system. These practices are designed to recognize the unique demands of each role and maintain alignment with industry standards, further supporting the Port's goal of fostering a motivated and equitable workplace.

Merit-Based Step System

The Port employs a seven-step compensation range with two longevity steps for each job classification. Each step within this system is differentiated by a 5% merit-based increase. Additionally, a possible annual Cost of Living Adjustment (COLA) may be applied to the compensation range once approved during the Budget process by the Board of Commissioners. (CPI Rate for All Urban Consumers – West – Size Class B/C)

Key points of the Merit-Based Step System include:

- **Performance-Based Promotion:** Advancement to the next step is not automatic. It is contingent upon the employee's satisfactory annual performance evaluation and the successful completion of any required training or certifications as directed by the supervisor or the Executive Director. See Value Based Compensation for Specific Training and Certifications in Additional Compensation: Other Benefits section for more details.
- **Longevity Steps:** Employees at the top of their range (Step 7) for three years are eligible for a 5% longevity increase. After an additional five years, another 5% longevity increase may be granted. In cases of exceptional performance, the Executive Director has the discretion to move an employee into the longevity step even if they are currently frozen at Step 7.

- **Initial Placement:** Employees may be hired at any step between Steps 1 and 7, depending on their knowledge, skills, abilities, and certifications, with longevity steps applied thereafter.

For any questions or further clarification regarding the Merit-Based Step System, employees are encouraged to consult with their supervisors.

Paydays

The Port operates on a 14-day payroll system. Each pay period begins on a Sunday and runs through the second Saturday, covering a 14-day period. Payday is the Wednesday following the end of each pay period. Employees must submit their time records by the end of the last day of the pay period; this deadline is subject to change. In the event of a holiday, the Finance department will notify employees of any changes to the submission deadline. There are 26 pay periods in a calendar year.

Payroll Deductions

The Port deducts various amounts from each employee's earnings in accordance with state and federal law. These deductions include state and federal income taxes, Social Security, Medicare, Worker's Benefit Fund, Paid Leave Oregon, and Public Employees Retirement System (PERS) contributions once eligibility is met. Employees may also authorize additional deductions in writing to cover costs associated with participation in Port-provided programs, such as insurance and retirement benefits. For questions regarding deductions, employees are encouraged to contact the Human Resources delegate.

Pay Advances

Employees may request a pay advance for unforeseen financial emergencies. Requests must be submitted in writing to a supervisor or the Human Resources delegate, specifying the reason and amount. Approval is not guaranteed and is subject to review. If approved, the advance will be deducted from future paychecks. Excessive requests may impact eligibility for future advances and could result in disciplinary action. Contact your supervisor or the Human Resources delegate for more information.

Method and Delivery of Payment

The Port primarily uses direct deposit for delivering employee wages, with payroll funds electronically deposited into designated bank accounts on scheduled pay dates. Employees are responsible for ensuring their direct deposit information is current and must submit any changes to the Payroll Department in advance to avoid payment delays. For employees who do not use direct deposit or in cases where direct deposit is not possible, physical paychecks will be available for pickup at the Port office on the scheduled pay date. Earnings statements are available to employees on pay dates. For assistance, employees can contact the Finance Department.

Employee Withholding Allowance Certificates (Form W-4)

The Employee Withholding Allowance Certificate (W-4) is provided at the time of hire and must be completed and signed by the employee before the start of the first workday. Changes can be made during the year by completing a new W-4 form. A copy will be placed into the employee's personnel file. At the end of each calendar year, you will be supplied with your Wage and Tax Statement (W-2) form.

Final Paycheck

While the Port requests that employees provide at least 10 working days' advance notice prior to departure when resigning or retiring, if an employee provides at least 48 hours' notice (excluding holidays and weekends), they will receive their final paycheck on the last day worked. If less notice is given, the final paycheck will be provided within five business days (excluding weekends and holidays) or on the next regularly scheduled payday, whichever occurs first. Final paychecks will be delivered based on the employee's default method of payment and will include all wages earned through the last workday plus payment for any eligible accrued and vested benefits that are due and payable at separation.

Paycheck Errors

The Port makes all efforts to comply with applicable Oregon and federal wage and hour laws. In the event you believe that the Port has made any improper deductions, has failed to pay you for all hours worked or for overtime, has failed to pay you in accordance with the law, or has failed to properly calculate your wages in any way, you must immediately report the error to the Human Resources delegate. The Port will investigate all reports of improper pay practices and will reimburse employees for any improper deductions or omissions. No employee will suffer retaliation or discrimination for reporting an error or complaint regarding the Port's pay practices.

HOURS OF WORK AND WORK SCHEDULES

The Port operates Monday through Friday from 9:00 AM to 5:00 PM, with additional operations at the Tollbooth and Facilities on weekends. Due to the diverse nature of services and operations, work schedules may vary based on job responsibilities and departmental needs. Certain positions may require specific shift times to ensure continuous service, while others may allow for more flexible scheduling.

Four-Tens Workweek Model

The Port may offer a "four-tens" workweek model, allowing employees to work four ten-hour days, followed by three consecutive days off. This model maintains a 40-hour workweek while providing employees with an extended break. Participation in this schedule is subject to supervisory approval and depends on operational requirements. Employees must ensure that their adjusted work hours do not disrupt the Port's services, and any changes may be reviewed to ensure alignment with business needs.

Time Records

Non-exempt employees must maintain accurate timesheets that record hours worked and any leave taken. These timesheets serve as legal records and are used to calculate pay and benefits in accordance with federal and state laws. Completed and approved timesheets must be submitted by the designated payroll deadline. Hours worked, paid time off (PTO), overtime, and compensatory time (if applicable) must be accurately documented, including start/end times and meal breaks. Any corrections should be promptly reported to the supervisor. Falsifying or altering timesheets is prohibited and may result in disciplinary action, up to termination.

Exempt employees work under a "professional workweek" model, where compensation is based on job duties rather than hours worked. Exempt employees must track their time based on projects or departments using a designated timesheet. PTO is used for vacation or sick leave absences exceeding four hours, with no deductions required for shorter absences unless they exceed 12 incidents annually.

Overtime and Compensatory Time

Non-exempt employees are eligible for overtime pay at a rate of 1.5 times their regular pay for hours worked beyond 40 in a given workweek, with leave such as vacation and sick time not counting toward the 40 hours. If a holiday occurs during the week and additional hours are worked, overtime pay will apply, even if total hours do not exceed 40. Overtime work must be pre-approved by a supervisor. As an alternative to receiving overtime pay, non-exempt employees may opt for compensatory time ("comp time"), which is accrued at the same 1.5 rate. Employees may accumulate up to a maximum of 40 hours of comp time. Additionally, non-exempt employees can adjust their work hours within the same workweek, such as working extra hours on one day and fewer hours on another, provided that total hours do not exceed 40. This adjustment also requires prior approval from a supervisor. Any unused comp time will be paid out upon termination of employment.

Exempt employees, on the other hand, are not eligible for overtime pay or comp time. However, they may accrue additional time off for extended hours worked beyond their regular schedule. This additional time must be approved by a supervisor in advance. Exempt employees may use the accrued time at a later date, and it should be tracked to maintain a healthy work-life balance. The accumulated time off for exempt employees may not exceed 40 hours and is subject to different guidelines than those for non-exempt employees.

Holiday Pay and Truck Roll

Non-exempt employees that work on Port approved holidays and perform off-hours truck roll mobilization for emergency response will be compensated at double the regular rate (x2.0).

On-Call Compensation

Non-exempt employees assigned to on-call duty, responsible for 24-hour emergency response for Port buildings and facilities, will receive \$200 for each pay period of on-call duty. During this period, on-call employees are expected to be accessible, available, and ready to return to work immediately if needed. They must carry the Facilities Department emergency phone and respond to all calls 24/7.

For any emergency requiring an off-hours response, on-call employees will be compensated at double their regular rate, with a minimum of one hour for each incident. Time is calculated from when they leave home until they return. If an emergency occurs during their standard shift, immediately after, or while the employee is already present on the Port premises, any additional hours worked will be compensated at the standard overtime rate.

Meal and Rest Periods

All non-exempt employees are required to take an unpaid 30-minute meal period when their work period is six hours or greater. Supervisors will provide information on the assigned time and length of the meal period. Under Oregon law, the meal period must be uninterrupted, with the employee fully relieved of all duties. If the work period is less than six hours, no meal period is required.

The Port has claimed an “undue hardship” exception for meal periods with Bureau of Labor and Industries (BOLI), as allowed by Oregon law, due to the significant difficulty or expense this would impose on the operation. Specifically for Toll Collectors and seasonal employees, when providing an uninterrupted meal period would impose an undue hardship, the Port will still ensure that non-exempt employees have adequate time to rest, consume a meal, and use the restroom, without any deduction from pay. If an employee is required to remain on duty or perform any tasks during the meal period due to the nature of the work, the employee must inform their supervisor before the end of the shift so that the Port can compensate the employee for that time.

In addition to meal periods, all non-exempt employees are entitled to two paid, uninterrupted 10-minute rest breaks (or the equivalent in smaller increments) for every four-hour segment, or major portion thereof, worked in a work period. Rest breaks should be taken in the middle of each segment whenever possible. For example, employees working a four-hour shift are entitled to one 10-minute rest break, and employees working a six-hour shift are entitled to one 10-minute rest break along with a 30-minute unpaid meal period.

For weekend shift Toll Collectors, meal breaks are scheduled from 10:00-10:30 a.m. and 6:00-6:30 p.m., and during these periods, ancillary fees for cash-paying customers are waived to accommodate booth closure. The above times are subject to change.

Meal periods and rest breaks are mandatory and cannot be combined into a single break or skipped to adjust start or end times. Failure to comply with this policy or applicable laws may result in disciplinary action, up to and including termination.

Rest Breaks for Expression of Breast Milk

The Port promotes and supports the practice and need for employees to express breast milk on its premises upon their return to work. Until their child is 18 months old, employees may take reasonable rest periods to express breast milk. Rest periods to express breast milk may be taken concurrently with regular meal and rest breaks, although additional reasonable break time will be made available, as needed. Management and employees will work together to find mutually agreeable hours of work and breaks which support the continuation of expressing breast milk.

The Port will make a reasonable effort to provide the employee with a private location within close proximity to the employee's work area to express milk. For purposes of this policy, “close proximity” means within walking distance from the employee's work area that does not appreciably shorten the rest or meal period. A “private

location” is a place, other than a public restroom or toilet stall, near the employee’s work area for the employee to express milk concealed from view and without intrusion by other employees or the public.

If a private location is not within close proximity to the employee’s work area, the Port will identify a private location the employee can travel to. The travel time to and from the private location will not be counted as a part of the employee’s break period. Hand washing facilities and a refrigerator will also be available at all sites and appropriate signage for privacy will be supplied.

Notice

An employee who intends to express milk during work hours must give their supervisor or Human Resource delegate reasonable oral or written notice of their intention to do so in order to allow the Port time to make any preparations necessary for compliance with this rule.

Storage

Employees are responsible for storing expressed milk. Employees may bring a cooler or other insulated food container to work for storing the expressed milk. If an office provides access to refrigeration for personal use, an employee who expresses milk during work hours may use the available refrigeration but should clearly label any containers with employee name. To ensure the safety of stored breast milk, it is recommended that the container used to store the milk be sealed in a plastic bag to prevent contamination.

Social and Recreational Activities

Participation in off-duty social or recreational activities such as organization picnics and holiday parties is entirely voluntary. Participation or nonparticipation will not affect your wages, hours, working conditions, or present or future employment opportunities.

Inclement Weather Attendance: Office Closure for Normal Business

In the event of inclement weather necessitating the closure of the office for normal business, essential personnel are required to report while non-essential personnel are excused. Specific Maintenance staff (as defined in position descriptions) and possibly some office staff are considered essential and must report during inclement weather events.

- **Non-Exempt Employees:** If the Port closes the office due to inclement weather, any missed work time will be deducted from the employee’s accrued, unused PTO. If the employee has depleted their PTO, they may use leave without pay. Management has the discretion to make this time paid if deemed appropriate.
- **Exempt Employees:** During office closures due to inclement weather, any missed work time will be deducted from the employee’s accrued, unused PTO. If the employee has exhausted their PTO, no deduction will be made to their salary. Management has the discretion to make this time paid if deemed appropriate.

The Executive Director reserves the right to require non-essential employees to work during office closures, alter shifts, or perform duties beyond their normal scope until the inclement weather situation subsides. All employees working during office closures will be compensated at their regular rate of pay.

Inclement Weather Attendance: Office Open for Normal Business

For the safety of all Port employees, accrued PTO may be used when severe travel advisories are in effect due to inclement weather. Employees must notify their supervisor on or before their scheduled start time if they are unable to safely travel to work. As a public agency, the Port is required to maintain services to its customers regardless of weather conditions, including snow, ice, and storms. Employees are expected to arrange suitable transportation during inclement weather to ensure attendance, as their presence is necessary to maintain service.

Employees are responsible for managing personal circumstances, such as distance, vehicle equipment, or school closures, to arrive at work as scheduled. On the first day of inclement weather, employees may receive up to a

one-hour "grace" period for late arrival, but on subsequent days, they are expected to make necessary arrangements to be at work on time. Compensation will be provided only for actual hours worked, following standard Port payroll policies for non-exempt and exempt employees.

If an employee cannot travel safely due to unique conditions at their home location, they must contact their supervisor at least one hour before their scheduled start time. Any missed work time due to inclement weather will be deducted from the employee's accrued, unused PTO.

Inclement Weather Attendance: Office Closed Early

If the Port closes the office before the normal end of the workday, on-duty non-essential personnel are excused unless instructed otherwise by the Executive Director. These employees will be paid for the remainder of their scheduled shift without needing to use paid leave. Non-exempt personnel who are required to remain on duty must continue working for the remainder of their scheduled shift and will be paid at their regular rate.

Employees will be notified by 7 a.m. via email to their Port inbox, or through a notification in their online employee portal, to confirm whether the office is open for normal business. The message will include any instructions regarding the Port's operations.

TELEWORK OR TELECOMMUTE

Both telework and telecommuting offer flexibility that may be available to certain positions within the organization. These are distinct arrangements:

- **Telework:** The planned practice of regularly working from a non-organization address, typically the employee's residence.
- **Telecommute:** The planned practice of occasional or intermittent work from a non-organization address, typically the employee's residence.

All telework and telecommuting arrangements require prior written approval from the supervisor and may be modified at the discretion of the Executive Director or designee. These arrangements may be permissible for some jobs but not all. Employees are responsible for ensuring a safe work environment when teleworking or telecommuting and must meet job expectations regardless of their work location. Supervisors are responsible for monitoring compliance with these agreements, relevant policies, performance standards, expectations for work product and productivity, and time accountability.

Employees who telework or telecommute must be available during established work hours and provide timely responses to emails, phone calls, etc. Any absences, including unavailability during work hours, must be pre-approved. Employees must accurately account for all time worked. Supervisors should evaluate requests to alter regular work hours for teleworking or telecommuting employees in the same manner as they would for those working at the Port's address. An employee's salary, benefits, and insurance coverage do not change as a result of teleworking or telecommuting.

Employees are responsible for using Port networks in a safe and secure manner as directed by the Port's IT consultant.

As mentioned above, these are planned arrangements. Employees and supervisors must collaborate to determine if an arrangement can be made and to establish the details of the arrangement.

Information Technology

Employees who telework or telecommute are expected to set up a remote office and use both organization-provided and personal equipment without direct physical assistance from the Port. While the Port will maintain any equipment it supplies, employees are responsible for the safe and secure transportation of equipment to and from the office. Employees must have sufficient telephone arrangements to perform their work and

participate in telephone conferences during agreed-upon work hours. Additionally, employees must have adequate Internet access if their work assignments require the use of web resources while working remotely.

The Port will determine, with input from the employee and the supervisor, what equipment will be supplied for each telecommuting situation. Employees are required to sign an Equipment Inventory form⁶, affirming responsibility for the equipment and agreeing to return it in its original condition upon request or termination of employment.

All Port-supplied equipment will be maintained by or at the direction of the Port. Equipment supplied by the employee will be maintained by the employee. The Port accepts no responsibility for damage or repairs to employee-owned equipment. All equipment and software supplied by the Port are for Port business only and must comply with the Port's security and maintenance policies and practices. Portable equipment must have Port-authorized security measures installed and running at all times. If the teleworking employee provides their own equipment, it must comply with the Port's security and maintenance policies and practices, as well as any additional safeguards required by the Port. Employees must notify the Port immediately in the event of a breakdown or other issue with supplied equipment, software, or other materials. Employees will follow the Port's direction regarding any necessary repairs, updates, replacements, etc. Upon separation of employment or the discontinuation of a telework arrangement, all Port property issued to the teleworking employee must be returned. Port data stored on any employee's personal electronic equipment is subject to public records requests and discovery and may be reviewed by the Port at any time.

Security

Employees are expected to ensure the protection of Port and district information accessible from their home office.

Steps include making sure that:

- All devices have anti-virus software
- All Wi-Fi, cellular or similar access points are protected with strong passwords or passphrases.
- All Wi-Fi, cellular or similar access point passwords or passphrases are changed on a regular and scheduled basis.
- Login and password information is secure and protected, even from family members.
- Basic network practices are being applied [firewall with appropriate security standards].
- Web-based systems are secure [“https” URL, not just “http”].
- Two factor authentication is enabled and being used [if available].
- All data is saved to Port authorized shared network drives or cloud locations. Similarly, no data is saved or stored on portable machines.
- VPN access [if available] is only via the Port issued devices. No personal devices are connected via VPN.

For further details, employees are encouraged to contact the Port's IT Consultant.

Physical Security

Employees are expected to ensure physical office security by taking measures such as keeping proprietary materials in locked file cabinets and desks, securing doors and windows, concealing devices when not in use, and implementing any other appropriate security measures for the job and environment.

Employees must follow all Port policies related to information and data security. Complying with these policies mitigates risk and ensures an appropriate level of security for confidential information, both paper and electronic, whether in transit or at an alternate worksite. When accessing the Port's network from a personal computer, employees are responsible for preventing access to any computer resources or data by unauthorized users. Additionally, employees must ensure the remote host is not connected to any other network simultaneously,

⁶ R:\Archives\Administrative Records\Templates & Forms\Human Resources\Equipment Inventory Form

except for personal networks that are under their complete control or under the complete control of the employee.

Performing illegal activities through the Port network or on Port time is strictly prohibited. Employees bear responsibility for and the consequences of misuse of their access. The IT Consultant will confirm that the user's device does not contain any traces of protected, sensitive, Port, or proprietary information and will delete any such data, licensing, and information remaining on the device.

Technology Support

The IT Consultant will only provide device support that relates to the Port devices and connection.

EMPLOYEE-INCURRED EXPENSES AND REIMBURSEMENT

The Port will cover all actual and reasonable business-related expenses incurred by employees while performing their job responsibilities. All such expenses must be pre-approved by the employee's supervisor prior to payment.

Expense Reimbursement Procedure and Reports

Requests for expense and mileage reimbursement must be submitted at least quarterly. Each request must include supporting documentation and/or itemized receipts. Expense reimbursements will not be processed unless all itemized receipts are provided. If receipts are lost, a note detailing the business activity and expense must be submitted.

Mileage Reimbursement

Employees may use their personal vehicles for Port-related business purposes with supervisor approval. Please refer to the "Driving While on Business" section for more details.

Employees will be reimbursed for mileage when using their personal vehicles for approved travel related to Port business, such as attending meetings, visiting job sites, running work-related errands, or any other travel directly tied to fulfilling their job responsibilities. Reimbursement will be at the current IRS-determined rate per mile. To recover these costs, an expense report must be signed and dated by the employee, initialed by their supervisor, and submitted to the Finance Department for processing according to policy. Employees with questions about expense reports and mileage allowances should consult their supervisor.

Credit Card Payment

If a credit card is provided to an employee, all receipts must be submitted monthly to the employee's supervisor for the credit card reconciliation process. Employees must adhere to the protocol for reconciliation of their statement and submission of required documentation, which may include the use of an electronic system provided by the financial institution tied to the credit card. Employees may expense and/or use a company-provided credit card for Port-related business activities or incidental supplies only in accordance with IRS guidelines. A credit card agreement is signed prior to the card being issued to the employee. Employees are not allowed to use Port's credit card for personal purposes.

Overnight Travel and Meal Expense Reimbursement

Employees traveling overnight on Port-related business activities will be reimbursed for lodging, meals, and incidental expenses based on the per diem rates set by the IRS. These per diem rates cover the costs of lodging, meals, and incidental expenses such as tips and fees. Employees should refer to the current IRS per diem rates for the specific location of their travel. Employees do not need to keep receipts for expenses covered by the per diem rate. However, to ensure the per diem is nontaxable, employees must submit an expense report to the employer detailing the dates, locations, and business purpose of the travel. [Link to the expense report⁷](#) can be found below.

⁷ R:\Archives\Administrative Records\Templates & Forms\Human Resources\Expense Reimbursement Request Per Diem

Exceeding Per Diem Limits

There may be certain group meal functions at conference or training locations where exceeding the per diem limits is acceptable. Such situations should be known in advance, and prior approval must be obtained from the Executive Director or designee. Additionally, receipts must be submitted as part of the expense reimbursement request.

Alcoholic Beverages

The Port will not reimburse costs for alcoholic beverages, and such expenses should not be submitted for reimbursement.

Transportation Expense Reimbursement

Transportation costs, including airfare, airport parking, hotel shuttles, automobile rental, and fuel for rental vehicles, may only be expensed with prior written approval.

As part of each employee's official compensation package, employees may retain any travel benefit program rewards such as frequent flier miles for the employee's own personal use. If the employee receives such travel benefit awards for their personal use, the employee may need to report the value of such rewards for income tax purposes. If an employee receives compensation from a carrier for delay or cancellation of travel, or similar situation, the employee may retain such compensation for delay or cancellation provided there was no increased cost to the Port. Any vouchers for unused transportation or lodging paid for by the Port are the property of the Port.

Spouse/Guest Expense Reimbursement

The Port will not pay for meals or entertainment expenses of spouses, guests, or significant others. The Port expects its employees to use good judgment and reserves the right to deny an expense if it is deemed unreasonable by management.

BENEFITS

ADDITIONAL COMPENSATION: BENEFITS

The Port strives to provide equitable and cost-effective benefits for employees in recognition of the influence benefits have on employees' economic and personal welfare. Paid in various benefit forms on behalf of employees, the total cost of providing the benefit program is a significant supplement to pay and should be viewed as additional compensation.

Policies, provisions, and procedures that govern the Port's benefit program apply to all regular full-time and part-time employees, whether exempt or non-exempt, unless otherwise stated in a particular benefit plan. Benefits do not apply to temporary or on-call employees.

Some benefits may accrue during the new-hire introductory period, but in most cases, eligibility to use these benefits will not occur until an employee obtains regular employee status or meets other conditions of employment specified in the Handbook or contained in the benefit policy/plan booklets.

Benefit Pro-Ration and Employee Cost Sharing

Discretionary employee benefits not mandated by state or federal law are selected and controlled by the Port. Decisions to provide these benefits are based on considerations such as cost, composition of the workforce, operational efficiency, and desirability of benefit provisions. When the costs of discretionary insurance benefit plans exceed the Port's interest in or ability to pay the full premium, employees will be required to share in the cost of their coverage.

Benefit Design and Modification

The Port reserves the right to design plan provisions and to add, eliminate, or otherwise modify the benefits described in this Handbook or elsewhere in plan documents when it is in the Port's best interest. Employees should consider that changes to benefits may occur at management's discretion before making serious, long-term decisions based solely on current benefit offerings.

Benefit Plan Documents

Employees will receive summary plan descriptions upon eligibility and enrollment. The benefit programs are explicitly defined in legal documents, including insurance contracts, official plan texts, and trust agreements. In the event of a conflict between these documents and this policy, the plan documents govern. These official documents are available from SDIS – Special District Insurance Services or current insurance provider for review. Employees are asked to refer any questions about this information to the Human Resources delegate.

Benefit Changes and Continuation

Individual benefits may be modified, become more expensive, or may even be eliminated in the future because of cost increases or as a result of changes in the business situation or economic conditions. Employees are encouraged to be thoughtful about relying solely on these benefits, given that they are subject to change. Upon separation from employment, employees may be eligible for the continuation of benefits consistent with state and federal law. Any benefits described in this Handbook apply only so long as the Handbook is current; employees do not have vested rights.

HEALTH INSURANCE BENEFIT

Medical, Dental, Vision Insurance Overview

The Port provides a comprehensive package of employee benefit programs. Complete and official details of insurance plans are contained in separate documents, copies of which employees receive on their first day of work or when programs are changed. The descriptions of these benefits that follow are brief summaries for general information.

The Port offers a comprehensive healthcare insurance program for employees, their spouses, and/or children. This program is available to all regularly scheduled, non-seasonal, non-temporary employees working 30 hours per week or more. Medical, Dental, Vision, and an Employee Assistance Program are included in the healthcare offerings. Employees pay 10% of the healthcare premium cost for themselves and/or for optional coverage for a spouse and children. Election coverage information is provided at the time of hire, available during an annual election period, and in the event of significant events defined in the insurance coverage.

The Port seeks to manage benefit costs while providing a comprehensive benefit package. The Port reviews total expected benefit costs each budget year. If the annual growth rate of benefits is within a reasonable and expected rate, the Port will continue to pay 90% of premium costs for medical, dental, and vision insurance. If the growth rate exceeds a reasonable rate and is expected to continue to do so, the Port will explore and implement alternative and appropriate cost-sharing strategies for premiums with staff.

Benefits become effective on the first of the month following the date of hire unless the date of hire is the first workday of the month, whereby the effective date is the first of the month. For more details and official terms of these plans, employees should refer to the plan booklet received on their first day of work or contact the Human Resources delegate.

The existence of these employee benefits and plans does not guarantee that an employee will be employed for the requisite time necessary to qualify for these benefits and plans.

COBRA

The group health insurance program may be continued at the employee's cost if employment with the Port ends under circumstances described by federal law (COBRA). Employees and their eligible dependents will receive a detailed explanation of this privilege upon termination of employment.

Life, LTD, ADD

The Port provides basic coverage for life insurance and short-term disability insurance for all regularly scheduled, non-seasonal, non-temporary employees. For exempt employees, the Port pays for long-term disability insurance. Specific information on each coverage is provided at the time of hire and is available from the Human Resources delegate.

Flexible Spending Accounts

The Port provides both a medical Flexible Spending Account (FSA) and a Dependent Care Assistance Program (DCAP) for employees. Annual enrollment is required each year to utilize this benefit. Employees should see the Human Resources delegate for specific information on each account.

OTHER INSURANCE BENEFITS

State Unemployment Insurance

The Port participates in a self-funded State Unemployment Insurance program that adheres to all applicable state regulations and requirements. This program provides weekly benefits to employees who become unemployed through no fault of their own or under circumstances outlined by state law. Eligibility and benefit duration are

determined by state guidelines and the employee's work history. Employees with questions about unemployment benefits can seek assistance from the Human Resources delegate.

Workers' Compensation

The Port is committed to the safety and well-being of its employees by providing comprehensive Workers' Compensation insurance coverage. This insurance covers medical treatment and part of any income lost due to work-incurred injuries or illnesses. Specific benefits are determined by state laws and vary based on the nature and severity of the incident.

To ensure maximum coverage and a smooth claims process, employees must: (1) report any work-related accidents or illnesses immediately to their supervisor and the Human Resources delegate; (2) seek medical treatment and follow-up care if necessary; and (3) promptly complete a written Employee's Claim Form (Form 801). Prompt reporting ensures accurate documentation and timely medical intervention. The Port also emphasizes creating a safe work environment through adherence to safety regulations, regular training sessions, and promoting a culture of safety awareness.

Return to Work

If an employee requires workers' compensation leave, they will — under most circumstances — be reinstated to the same position held at the time the leave began or to an equivalent position, if available. However, the employee must first provide documentation from a healthcare provider familiar with their condition certifying their ability to return to work and perform the essential functions of the position.

When returning from workers' compensation leave, employees have no greater right to reinstatement than if they had been continuously employed. For example, if the employee would have been laid off during the leave, or if the position is eliminated and no equivalent or comparable positions are available, reinstatement may not be guaranteed. The Port does not discriminate against employees who experience a workplace injury or illness.

Early Return to Work

The Port's Return-to-Work program provides guidelines for returning employees to work as soon as possible after an on-the-job injury or illness resulting in time loss. This program is not a substitute for reasonable accommodation when the injured employee also qualifies as an individual with a disability. The program is designed as transitional work to facilitate an employee's return to their regular job within a reasonable time frame. The Return-to-Work program for job-related injuries is a collaborative effort involving the Port, injured employees, their treating physicians, and the workers' compensation insurance carrier claims staff. The goal is to return employees to full employment as early as possible, consistent with their medical condition and the advice of the treating physician.

If an employee's doctor determines that they are able to perform modified work, the Port will attempt to provide a temporary job assignment for a reasonable period until the employee can resume regular duties, except when accommodations are needed for a disability. If an employee is offered a medically approved modified position due to a work-related injury, failure to phone in or report at the designated time and place may impact their compensation and employment with the Port. While working in a modified or transitional role, the employee remains subject to all other Port rules and procedures.

Overlap with Other Laws

The Port will take into account other applicable leave and disability laws, such as the Americans with Disabilities Act (ADA), the Oregon Family Leave Act (OFLA), or Paid Leave Oregon, that may apply to an employee's situation. If, after returning from workers' compensation leave, it is determined that the employee is unable to perform the essential functions of their position due to a qualifying disability, they may be entitled to a reasonable accommodation, as governed by the ADA and/or applicable Oregon laws covering workplace disabilities.

For detailed information regarding workers' compensation benefits and procedures, employees should refer to the official plan documents or contact the Human Resources delegate. The Port is committed to providing the necessary support and care in the event of a work-related injury or illness.

PAID TIME OFF (PTO) POLICY

The Paid Time Off (PTO) program provides paid time off to be used at the employee's discretion while protecting an allotment of time for illness, injury, or preventative care, in compliance with applicable sick time regulations. PTO is a combination of vacation and sick time days. The Port provides a PTO program to offer employees flexibility in managing their time away from work for any purpose, including vacation, illness, personal appointments, or other personal needs. This policy ensures a stable income during these periods and promotes work-life balance.

Eligibility:

All employees are eligible for PTO accrual, with rates that vary based on the employee's classification and comply with Oregon Sick Leave Law.

PTO Accrual Rates for Full-Time Employees:

- 1st through 12th month (1st year): 5.33 hours per pay period (3.08h vacation + 2.67 sick)
- 13th through 60th month (2-5 years): 6.50 hours per pay period (3.69h vacation + 2.67 sick)
- 61st through 120th month (6-10 years): 7.38 hours per pay period (5h vacation + 2.67 sick)
- 121st through 180th month (11-15 years): 8 hours per pay period (6h vacation + 2.67 sick)
- 181st through 240th month (16-20 years): 8.67 hours per pay period (7h vacation + 2.67 sick)

PTO Accrual for Part-Time and Seasonal Employees:

Eligible employees working 32 hours a week or more accrue PTO at the same base rate as full-time employees, pro-rated based on actual hours worked. No PTO accrues during unpaid leave.

Sick Leave for All Employees:

In accordance with Oregon Sick Leave Law, all employees, regardless of classification or hours worked, are eligible to accrue sick leave. Employees accrue a minimum of one hour of sick leave for every 30 hours worked, up to a maximum of 40 hours per year. This applies to both full-time and part-time employees, ensuring access to paid sick leave for personal or family health needs.

Accrual Start Date:

Accrual begins on the first day of employment, but employees are not eligible to use PTO until the 90-day period has been successfully completed or negotiated during the hiring process.

PTO Usage:

PTO can be used for any purpose, including vacation, illness, medical appointments, personal time, or family care. PTO must be scheduled and approved by the supervisor in advance when possible. For unscheduled absences, employees must notify their supervisor as soon as possible.

Required Notice for Time Off:

- **Illness/Injury:** Two (2) hours prior to the start of the shift
- **Planned Needs:** Two (2) weeks

PTO time is considered replacement time and may be taken only for scheduled workdays and hours. The notice schedule should provide time for departments to arrange for adequate coverage during employee absences. However, if management is unable to schedule time off, requests may be denied even though sufficient advance notice has been given. If more than one employee in a department asks for the same time off and gives the required advance notice, length of service within the department will be considered in granting the requests. PTO must be used in increments of 30 minutes or more.

PTO Payment:

All PTO will be paid at an employee's regular rate of base pay, including applicable shift differentials.

PTO Year-End Options:

At the end of the calendar year, employees (both full-time and part-time) with unused PTO hours have the following options:

- **Transfer to Disability Bank:** Employees can transfer unused PTO hours to the disability bank. These hours can only be used for extended absences due to illness, injury, or disability. Note that hours in the disability bank are not eligible for cash-out.
- **Carry Over to Next Year:** Employees may carry over up to 120 unused PTO hours to the next calendar year. These hours can be used for future time off and are eligible for cash-out.
- **Cash Out PTO:** Employees may opt to cash out any PTO hours above the 120-hour balance. These hours will be paid at their full value in a December paycheck. To cash out PTO, employees must maintain a minimum of 120 hours in their balance.

Employees must make their selection in November to allow for December payroll processing and PTO adjustments for the new year.

PTO Payout Upon Separation:

At separation, any unused "earned leave" PTO will be cashed out at full value. This policy ensures that employees are compensated for their accrued leave upon leaving the organization.

Extended Absence/Disability Bank:

The disability bank is part of the PTO Program and is for extended absences due to illness, injury, disability, or hospitalization, including pregnancy-related conditions. Employees can accumulate up to 1,040 hours (six months) in their disability banks and may donate time to others in need. No payment is made for unused disability bank hours upon separation.

The Port offers a sabbatical program for personal or professional development, study, research, travel, or rest. Sabbaticals are granted at the discretion of the Executive Director on a case-by-case basis, typically for employees with significant service, such as those with 10 or more years of continuous employment.

The duration of the sabbatical will be determined by the Executive Director, considering the employee's request and the operational needs of the Port. Sabbaticals are granted on case-by-case basis. With prior approval, employees may use their accrued Disability Bank PTO during their sabbatical. All sabbaticals require Executive Director approval to ensure appropriate coverage and business continuity.

Employee Responsibilities:

Employees are responsible for understanding and following the PTO policy, including notifying supervisors of absences, planning and scheduling PTO in advance, and ensuring they use their time off appropriately. Open communication with supervisors about health and leave needs is encouraged.

Additional Support:

The Port offers an Employee Assistance Program (EAP) for managing health issues, stress, and other personal challenges. Information about the EAP is available through Human Resources.

PAID HOLIDAY BENEFIT

The Port provides paid holidays to recognize and celebrate important national and cultural events, and to give employees time off for rest and personal activities.

Eligibility:

Full-time employees are eligible for the following paid holidays each calendar year, per the following schedule:

- New Year's Day (January 1)
- Presidents Day (Third Monday in February)
- Memorial Day (Last Monday in May)
- Independence Day (July 4)
- Labor Day (First Monday in September)
- Veterans Day (November 11)
- Thanksgiving Day (Fourth Thursday in November)
- Friday after Thanksgiving (Fourth Friday in November)
- Christmas Day (December 25)

When a Port holiday falls on a Sunday, the following Monday will be observed as the holiday. If a holiday falls on a Saturday, the preceding Friday will be observed as the holiday. A non-exempt employee working on a holiday will be paid double their regular rate of pay. Holidays are defined as the 24 hours beginning at midnight on the date of the holiday.

Floating Holidays

The Port provides floating holidays to offer full-time employees flexibility for personal needs or special occasions. Full-time employees receive five floating holidays per year, credited on January 1, which include recognition for Martin Luther King Jr. Day, Indigenous Peoples' Day, and Juneteenth. Employees hired after July 1 will receive two floating holidays in their first year; those hired before July 1 will receive five.

Floating holidays must be used by the end of the final pay period of each calendar year and cannot be carried forward or cashed out if unused. They must be used in 8-hour increments. Requests for floating holidays should follow the PTO procedures but may be approved with shorter notice if feasible. Employees are encouraged to schedule all floating holidays in advance to ensure adequate coverage and minimal disruption to operations.

While the Port offices remain open on Martin Luther King Jr. Day, Indigenous Peoples' Day, and Juneteenth, employees may request these days off following the PTO procedures, on a first-come, first-served basis.

Part-time employees who are scheduled to work on Martin Luther King Jr. Day, Indigenous Peoples' Day, or Juneteenth will receive double their base rate for any hours worked on those days.

OTHER BENEFITS

Employee Assistance Program

All full-time Port employees covered by the SDIS medical insurance program have additional wellness benefits available through our Employee Assistance Program (EAP). Provided by Canopy through SDAO/SDIS insurance, this program offers various services, including three free counseling sessions per year, available face-to-face, over the phone, or via video conference. These confidential sessions with professional mental health care providers are designed to support employees' mental health and well-being. Given the increased stress from the pandemic,

leadership changes, new roles and responsibilities, and busy summer seasons, employees are encouraged to take advantage of these resources. For more information, please contact the Human Resources delegate.

Retirement Plan

The Oregon Public Employees Retirement System (PERS) covers all employees in a PERS-qualified position who work at least 600 hours and more than six months in a calendar year. Employees are required to contribute 6% of their payroll once they become PERS members, and the Port also funds the PERS defined benefit of the pension plan, which is updated biennially. This plan ensures long-term financial security for employees. For further details about the Oregon PERS plan, employees can contact the Human Resources delegate or visit the Oregon PERS website at <https://www.oregon.gov/pers/Pages/index.aspx>.

Oregon Savings Growth Plan

Port employees have the option to participate in the Oregon Savings Growth Plan (OSGP), a voluntary 457(b) deferred compensation plan operated by the State of Oregon Retirement Systems. This plan allows employees to contribute pre-tax or post-tax (Roth) dollars to a retirement savings account, with a variety of investment options available. The OSGP is designed to supplement other retirement benefits, such as the Oregon Public Employees Retirement System (PERS), offering employees an additional way to grow their retirement savings and enhance their financial security. Employees interested in participating should contact the Human Resources delegate for more information and enrollment forms.

Uniforms, Boots, and Rain Gear

The Port provides uniforms, hats, and name tags to all personnel not only as a benefit to the employees but also to identify workers to the public. As representatives of the Port, these personnel are expected to represent the Port positively and professionally by wearing the uniform every day or displaying Port logo tags identifying them as Port employees. Maintenance personnel are required to use Port uniforms, hats, name tags, and safety equipment with the Port's logo while working in the field, as this is an expectation set by the Port and the Board of Commissioners.

Safety is a key objective of the Port, and all employees working in environments where foot injury could occur must wear appropriate work boots. Once a year, all Maintenance personnel are authorized to purchase one pair of steel-toed or work boots from a vendor of their choosing. The allowance amount will be determined on an annual basis and approved in Port's budget. Employees must pay any cost exceeding the authorized amount before ordering, while costs within the limit may be billed directly to the Port.

Employees are responsible for the reasonable care and maintenance of their boots, as with all personal protective equipment. Appropriate rain gear and boot tracks for ice will also be provided to field personnel. For any questions, employees should contact their supervisor.

Education and Training Assistance Program

The Port is committed to supporting the professional development and personal growth of its employees through various educational opportunities. Full-time and part-time employees in good standing are encouraged to enhance their job skills by participating in workshops, seminars, and other educational programs. At least once a year, employees are encouraged to attend a special training workshop or conference that directly relates to their role at the Port. Local opportunities are preferred, but if specialized training is unavailable locally, the Port may cover additional costs such as meals and lodging.

The Education Assistance Program is designed to encourage ongoing personal development and education, meeting the current and future needs of the Port, improving work performance and efficiency, and facilitating internal promotions. Employees seeking reimbursement for classes, seminars, educational programs, or certifications/tests must obtain prior written approval from the Executive Director or designee. Approval is also required for any program involving time away from work and related expenses.

Eligibility for education reimbursement extends to all regular full-time and part-time employees in good standing, provided the education is related to the employee's job position. However, training programs such as workshops,

institutes, seminars, and symposiums that do not meet the specific criteria for reimbursement can still be attended during regular work hours with the approval of the Executive Director or designee.

The program covers the cost of tuition, required textbooks, enrollment costs, and examination fees. Textbooks reimbursed by the Port become its property. Reimbursement is not provided if the employee is eligible for funding from other sources, though the Port may cover portions not covered by other sources up to the program's limit. The maximum annual reimbursement for job-related education is based on IRS guidelines.

Reimbursement is contingent upon the employee completing pre-approved, job-related classes with a passing grade of 'C' or better, or a "Pass" in ungraded courses. Employees may request reimbursement prior to starting a class, provided they show proof of active enrollment and submit a grading report upon completion of the coursework. If an employee voluntarily terminates employment within 90 days of completing a course, they must repay up to 75% of the reimbursed amount. The Port will bill the former employee for this repayment as it cannot be deducted from payroll.

For examinations or tests, the Port covers the fees once, regardless of the outcome.

Reimbursement under this program is excludable from the employee's taxable wages, as outlined in IRS Publication 15-B, Employer's Guide to Fringe Benefits. For more information or to submit funding requests, employees should contact their supervisor or the Human Resources delegate during the annual budget development process.

Value-Based Compensation for Specific Training and Certifications

The Port recognizes the importance of continuous professional development and specialized skills that enhance operations. To incentivize and reward employees for acquiring and maintaining valuable certifications and training, a value-based compensation program has been established. This program allows employees to earn pay increases upon successful completion of specific training courses and certifications that are deemed beneficial to Port operations.

Eligibility and Approval:

Opportunities for value-based compensation are job-specific and need-based, recommended by supervisors, and approved by the Executive Director. Compensation values for each training and certification will be determined by the Finance Director as part of the annual budget process. This list is not exhaustive and may change based on the evolving needs of the Port.

Compensation Opportunities:

• Facilities Department

- Basic Training (flat \$ amount per paycheck):
 - Flagger certification
 - Boater's License
 - Small Engine Repair Clearance
 - Heavy Equipment Operator Clearance
 - Tree and Shrub Pruning Clearance
 - Airport Tractor Mower Clearance

- Advanced Training (% of salary merit increase):
 - Electrician Certification: Comprehensive training in electrical systems, installation, and maintenance, ensuring adherence to safety standards and regulations.
 - CDL License (Commercial Driver's License): Certification allowing the operation of large or specialized vehicles, essential for various operational roles within the Port.
 - Plumbing Certification: Training and certification in plumbing systems, including installation, repair, and maintenance, critical for facility operations.

- Bridge Lift Operator Clearance: Specialized training for operating bridge lift mechanisms, ensuring safe and efficient operations.
 - Welding Certification: Advanced skills in welding techniques and safety, applicable to various maintenance and repair tasks.
 - HVAC and/or Refrigeration License: Certification in heating, ventilation, air conditioning, and refrigeration systems, ensuring climate control and system efficiency.
 - Confined Space Entry Certification: Training for safely working in confined spaces, including hazard recognition and emergency procedures.
 - Specific Job-Related Advanced Training as Determined by the Executive Director or designee: Tailored advanced training programs that address specific needs and roles within the Port.
- **Customer Service / Administration / Project Management**
 - Basic Training (flat \$ amount per paycheck):
 - Customer Service Training for Government Agencies
 - Computer Proficiency Test
 - Spanish / English Bilingual Test
 - Telephone Etiquette and Professional Communication
 - Digital Customer Service Skills
 - Ethics and Integrity in Customer Service
 - Time Management Skills Certification
 - Advanced Training (% of salary merit increase):
 - Certified Customer Service Professional (CCSP): Comprehensive certification covering advanced customer service skills, including problem-solving and communication.
 - Certified Customer Experience Professional (CCXP): Focuses on all aspects of customer experience management, including strategy, culture, and metrics.
 - Project Management Professional (PMP): Beneficial for managing customer service projects or teams, emphasizing project planning, execution, and leadership.
 - Six Sigma Certification (Green Belt/Black Belt): Focuses on process improvement and efficiency, enhancing operational effectiveness in customer service.
 - Lean Certification: Emphasizes streamlining processes and eliminating waste, improving customer service operations.
 - Certified Public Manager (CPM): Comprehensive management training program that enhances leadership and management skills.
 - Advanced Certificate in Strategic Management (ACSM): Equips employees with strategic management skills, useful for senior customer service roles.
 - Public Records/Retention and Public Meetings Law Certification: Training in compliance with public records laws, retention schedules, and the conduct of public meetings, ensuring transparency and legal adherence.
 - Principles of Procurement Certification: Comprehensive understanding of procurement processes, including sourcing, contract management, and ethical considerations, critical for managing purchases and vendor relationships.
 - Specific Job-Related Advanced Training as Determined by the Executive Director or Designee: Tailored advanced training programs that address specific needs and roles within the Port.
 - Completion of an Advanced College Degree in the Job Field: Recognizes the value of advanced academic qualifications in relevant fields, contributing to higher expertise and professional growth.

LEAVES OF ABSENCE

The Port recognizes that employees may encounter situations that require temporary short-term or extended absences from work. We offer several types of leaves of absence for various purposes, ensuring that our employees have the support they need during such times. The types of leaves available include:

- Bereavement Leave
- Disability Leave (Non-FMLA)
- Family and Medical Leave
- Civic Duty Leave
- Military Leave
- Donate Bone Marrow
- Personal Leave
- Crime Victims' Leave
- Domestic Violence Leave
- Paid Leave Oregon
- PTO (as described in previous section)

The type of leave requested may determine which employees are eligible and the procedures to be followed in requesting and obtaining the leave. The impact of the leave on benefit accruals, benefits, and reinstatement rights also varies according to the type of leave requested. Detailed information about each type of leave is provided in the following pages.

For any questions regarding eligibility for a leave of absence, the procedures to follow, or the benefits and rights available while on leave, please contact the Human Resources delegate.

BEREAVEMENT LEAVE

Eligibility:

Employees are eligible to take Bereavement Leave in the event of the death of the following immediate Family Members:

- Spouse/ Registered Domestic Partner
- Child or child's spouse or registered domestic partner (includes adopted, foster, biological or stepchild)
- Parent
- Grandparent/Grandchild
- Parent-in-law
- Someone who acted as a parent to the employee (in loco parentis), even if they are not the employee's biological parent
- An individual related by blood or affinity whose close association with an employee taking bereavement leave is the equivalent of a family relationship

Leave to attend the funeral of a non-immediate family member with whom the employee had an especially close relationship may also be granted at the discretion of management.

Purpose of Leave:

Bereavement Leave may be taken to:

- Attend the funeral or alternative ceremony of the family member.

- Make arrangements necessitated by the death of a family member.
- Grieve the death of a family member.

The leave must be completed within 60 days after the date on which the employee received notice of the death of their family member.

Length of Leave:

Employees who have worked for the Port for 180 calendar days, and averaged at least 25 hours per week, may take up to two weeks of unpaid bereavement leave per death of a Family Member. Employees who have worked for the Port for 90-180 days may use up to 40 hours of accrued paid time off for bereavement purposes, and who have experienced the death of a Family Member. Employees who have worked for the Port for fewer than 90 days may not be eligible for leave; see Human Resources delegate for more information.

Request Procedure:

If possible, the employee should provide notice of the need for leave 10 days in advance. At a minimum, the employee must provide oral notice within 24 hours of taking leave, though someone else can do this on their behalf if necessary. Written notice of the request for time off must be provided within three (3) days of returning to work.

Pay While on Leave:

Employees will continue to receive regular pay based on straight-time work hours missed, up to eight (8) hours a day, for up to three (3) days. These three days are included as part of the two weeks of bereavement leave allowed under the Oregon Family Leave Act (OFLA). Employees may choose to cover any additional period of absence beyond the three paid days with available Paid Time Off (PTO).

Status of Benefits:

Company-paid Bereavement Leave will not affect the employee's eligibility for benefits or the continuation of benefit accruals. If additional time off is granted, the effect on benefits will be determined by the Port's PTO, Sick Time, or OFLA policy.

CIVIC DUTY LEAVE

Jury or Witness Duty Leave

Purpose:

The Port provides protected leave of absence for employees subpoenaed to serve as witnesses or for jury duty. If the absence would cause undue hardship to the employee or the organization, the Port may request, with the employee's agreement, that jury duty be postponed. Employees may choose to use their accrued PTO leave for voluntary service as a witness or for their own legal proceedings or lawsuits.

Length of Leave:

Jury or witness duty leave is available for the period of time covered by the initial subpoena or court order and any involuntary extensions. Employees are expected to report for work when doing so does not conflict with court obligations. It is the employee's responsibility to keep their supervisor informed about the amount of time required for jury duty.

Request Procedure:

Employees must notify their manager or supervisor as soon as practicable after receiving notice to serve as a witness or on a jury so that arrangements can be made to cover their position. Employees are expected to provide a copy of the subpoena or notice within five (5) days of receiving it.

Pay While on Leave:

Non-exempt employees will be compensated for the difference between civic pay received and their regular rate of pay for up to two (2) weeks. After that period, employees may utilize paid time off if desired. For exempt employees, any partial day or partial week worked will be paid in full; employees are required to remit to the Port any jury fees received in connection with their service.

Status of Benefits:

Benefits are not affected by jury or witness duty leaves.

Voting Leave

Purpose:

The Port encourages all employees to vote and to take advantage of polling hours before or after work. If employees are unable to vote outside of business hours, the Port will accommodate them by arranging time for them to vote.

Request Procedure:

Employees must notify their supervisor before Election Day if they are unable to vote before or after work and provide a valid reason why voting during those hours is not possible.

Pay While on Leave:

Time off to vote will be without pay for non-exempt employees unless they have earned hours of vacation or personal time that they can use for that purpose.

CRIME VICTIM'S LEAVE & DOMESTIC VIOLENCE LEAVE

Crime Victim Leave Policy

Any employee who has worked an average of at least 25 hours per week for 180 days immediately before the date the employee takes leave is eligible for reasonable, unpaid leave to attend criminal proceedings if the employee or their immediate family member (defined below) has suffered financial, social, psychological or physical harm as a result of being a victim of certain felonies, such as kidnapping, rape, arson, and assault.

"Immediate family member" includes a spouse, registered domestic partner, father, mother, sibling, child, stepchild, or grandparent of the employee.

Employees who are eligible for crime victim leave must:

- Use any accrued, but unused vacation/sick leave during the leave period;
- Provide as much advance notice as is practicable of their intention to take leave (unless giving advance notice is not feasible); and
- Submit a request for the leave in writing to [Contact] as far in advance as possible, indicating the amount of time needed, when the time will be needed, and the reason for the leave.

In all circumstances, Port may require certification of the need for leave, such as copies of any notices of scheduled criminal proceedings that the employee receives from a law enforcement agency or district attorney's office, police report, a protective order issued by a court, or similarly reliable sources.

Domestic Violence Leave and Accommodation Policy

All employees are eligible for reasonable unpaid leave to address domestic violence or the crimes of harassment, sexual assault, bias or stalking (either the employee or the employee's minor dependents).

Reasons for taking leave include the employee's (or the employee's dependent's) need to: seek legal or law enforcement assistance or remedies; secure medical treatment for or time off to recover from injuries; seek

counseling from a licensed mental health professional; obtain services from a victim services provider; or relocate or secure an existing home.

Leave is generally unpaid, but the employee may use any accrued vacation or sick leave while on this type of leave. Employees should also determine whether Paid Leave Oregon may provide pay during this type of leave. See the "Paid Leave Oregon" policy for more information.

When seeking this type of leave, the employee should provide as much advance notice as is practicable of their intention to take leave, unless giving advance notice is not feasible.

Notice of need to take leave should be provided by submitting a request for leave in writing to the Human Resource delegate as far in advance as possible, indicating the time needed, when the time will be needed, and the reason for the leave. The Port will then generally require certification of the need for the leave, such as a police report, protective order or other evidence of a court proceeding, or documentation from a law enforcement officer, attorney, healthcare professional, member of the clergy, or victim services provider.

If more leave than originally authorized needs to be taken, the employee should give Port notice as soon as is practicable prior to the end of the authorized leave. When taking leave in an unanticipated or emergency situation, the employee must give verbal or written notice as soon as is practicable. When leave is unanticipated, this notice may be given by any person on the employee's behalf.

Finally, employees who are victims of domestic violence, harassment, sexual assault, bias crimes or stalking may be entitled to a "reasonable safety accommodation" that will allow the employee to more safely continue to work, unless such an accommodation would impose an "undue hardship" on Port. Please contact the Human Resources delegate immediately with requests for reasonable safety accommodations.

FAMILY AND MEDICAL LEAVE (OFLA)

The following is a summary of Oregon Family Leave Act (OFLA) policy and procedures. Generally, and as will be discussed, eligible employees are entitled to 12 weeks of unpaid leave for the reasons identified below. Oregon law prohibits retaliation against an employee with respect to hiring or any other term or condition of employment because the employee asked about, requested or used OFLA Leave. In all cases, applicable Oregon laws, rules, policies, and collective bargaining agreements govern the employee's and the City's rights and obligations, not this policy.

Employees seeking further information should contact the Human Resources delegate. Employees should also refer to the "Oregon Family Leave Act" notice posted in food prep room, the Maintenance Shop, and the Toll Booth which is incorporated here by reference.

Definitions:

Family Member - Is defined as a spouse or domestic partner, a child of a covered individual or the child's spouse or domestic partner, a parent of a covered individual or the parent's spouse or domestic partner, a sibling or stepsibling of a covered individual or the sibling's or stepsibling's spouse or domestic partner, a grandparent of a covered individual or the grandparent's spouse or domestic partner, a grandchild of a covered individual or the grandchild's spouse or domestic partner, any individual related by blood or affinity whose close association with a covered individual is the equivalent of a family relationship.

Child - Includes a biological, adopted, foster or stepchild, the child of a registered domestic partner, or a child with whom the employee is in a relationship of in loco parentis, under the age of 18 or over 18 if incapable of self-care because of a mental or physical disability.

Eligibility

OFLA - To qualify for OFLA leave an employee must have been employed for at least 180 days and worked an average of at least 25 hours per week.

OMFLA - For purposes of Oregon Military Family Leave Act leave, the employee need have only worked 20 hours per week (no minimum length of employment required). A different calculation method applies for reemployed service members under USERRA who seek OMFLA leave; see the Human Resources delegate for more information.

Public Health Emergency Leave - Employees are eligible to take any OFLA leave during a Public Health Emergency if they have worked: (a) more than 30 days immediately before the date on which the leave would begin; or (b) an average of 25 hours per week in the 30 days immediately before the date on which the leave would begin. See definition of “public health emergency” definition below.

Public Health Emergency

A “public health emergency” is a public health emergency declared under ORS 433.441 or an emergency declaration declared under ORS 401.165. An example of this is when the State of Oregon declared a COVID-19 state of emergency in March 2020 and the wildfire state of emergency in June 2021.

Reasons for Taking Leave

OFLA leave may be taken for any of the following purposes:

1. **Pregnancy Disability Leave:** For incapacity due to pregnancy, prenatal medical care or birth.
2. **Sick Child Leave:** To care for a child who suffers from an illness or injury that requires home care or has a serious health condition, or to care for a child whose school or place of care has been closed due to a public health emergency. This type of leave does not provide for routine medical and dental appointments or issues surrounding the availability of childcare when the child is not ill or injured.
3. **Bereavement Leave:** To deal with the death of a Family Member by attending the funeral of the Family Member, making arrangements necessitated by the death of the Family Member, or grieving the Family Member’s death. Employees are eligible for two (2) weeks per family member, up to a maximum of four (4) weeks per leave year.
4. **Oregon Military Family Leave Act Leave (“OMFLA”):** During a period of military conflict, as defined by the statute, eligible employees with a spouse or registered domestic partner who is a member of the Armed Forces, National Guard, or military reserve forces (“Military Spouse”), and who has been notified of an impending call or order to active duty (or who has been deployed) is entitled to a total of 14 days of unpaid leave per deployment after the Military Spouse has been notified of an impending call or order to active duty and before deployment and when the Military Spouse is on leave from deployment.
5. **Public Health Emergency Leave:** Employees are eligible to take any OFLA leave during a Public Health Emergency if they have worked: (a) more than 30 days immediately before the date on which the leave would begin; or (b) an average of 25 hours per week in the 30 days immediately before the date on which the leave would begin. This is available to employees who are eligible for OFLA only. See the definition of “public health emergency” below.

Length of Leave

In any One-Year Period, eligible employees may take up to 12 weeks of unpaid protected time off per leave year. Employees are eligible to take up to two (2) weeks of unpaid Bereavement leave, up to a maximum of four (4) weeks per leave year.

One-Year Period

For purposes of determining the amount of OFLA leave that an eligible employee may take, “One-Year Period” means a period of 52 consecutive weeks beginning on the Sunday immediately preceding the date on which the employee’s OFLA leave begins.

Intermittent Leave

Intermittent or reduced-schedule leave may be taken when medically necessary. Employees must make reasonable efforts to schedule planned medical treatments to minimize disruption of Port operations, including consulting management prior to the scheduling of treatment to work out a treatment schedule which best suits the needs of both Port and the employee.

Employee Responsibilities - Notice

Employees must provide at least 30 days' notice to their supervisor before OFLA leave is to begin. If 30 days' notice is not practicable, because of a lack of knowledge of approximately when leave will be required to begin or a change in circumstances, notice must be given as soon as practicable. If the situation giving rise to a Sick Child Leave is unforeseeable, an employee must give verbal or written notice to the Port within 24 hours of commencement of the leave.

Whether leave is to be continuous or is to be taken intermittently or on a reduced schedule basis, notice need only be given one time, but the employee shall advise the Human Resource delegate as soon as practicable if dates of scheduled leave change or are extended or were initially unknown.

If circumstances change during the leave and the leave period differs from the original request, the employee must notify their supervisor within three business days, or as soon as possible.

Regardless of the reason for leave, or whether the need for leave is foreseeable, employees will be expected to comply with Port's normal call-in procedures. Employees who fail to comply with Ports call-in procedures may be disciplined or may have their period of OFLA leave reduced.

Certification

Generally speaking, employees may be required to provide sufficient information for Port to determine if the leave may qualify for OFLA protection and the anticipated timing and duration of the leave. An employee will be required to provide a note from a doctor or healthcare provider if the employee has used more than three days (i.e., one, three-day occurrence or three separate instances) of sick child leave within a One-Year Period, Employees must furnish Port's requested medical certification information within 15 calendar days after such information is requested by Port.

Substitution of Paid Leave for Unpaid Leave

Employees are required to use accrued paid leave, including floating holidays, PTO, and compensatory time, prior to a period of unpaid leave of absence on OFLA leave. Accrued paid leave must be used in the following order: PTO, comp time, floating holiday, etc.

Holiday Pay While on Leave

Employees using PTO during a portion of approved OFLA leave in which a holiday occurs will qualify to receive holiday pay.

Benefits While on Leave

Port will continue the employee's health coverage under any group health plan during a period of approved OFLA leave on the same terms as if the employee had continued to work. The employee must continue to make any regular contributions to the cost of the health insurance premiums during the period of approved OFLA leave. Employees will not accrue PTO or other benefits (other than health insurance) while the employee is on an unpaid OFLA leave. The leave period, however, will be treated as continuous service (i.e., no break in service) for purposes of vesting and eligibility to participate in Port benefit plans.

Job Protection

Employees returning to work from OFLA Leave will be reinstated to their former position. If the position has been eliminated, the employee may be reassigned to an available equivalent position. Reinstatement is not guaranteed if the position has been eliminated under circumstances where the law does not require reinstatement.

Employees are expected to promptly return to work when the circumstances requiring OFLA Leave have been resolved, even if leave was originally approved for a longer period. If an employee does not return to work at the end of a designated OFLA Leave period, reinstatement may not be available unless the law requires otherwise.

The use of OFLA Leave cannot result in the loss of any employment benefit that accrued prior to the start of an employee's leave.

Restoration of Leave Bank at Time of Re-Employment

An employee who leaves employment with the Port for any reason may be eligible for OFLA leave if they are re-employed by the Port within 180 days of the separation and if the employee was eligible for OFLA leave at the time of the separation. Special rules apply to employees who temporarily stop working for the Port for 180 days or less; please speak with the Human Resource delegate for more information.

The best resource and the most up to date information about the Oregon Family Leave Act (OFLA) can be found at:

- **Oregon Bureau of Labor and Industries (BOLI) Website:** BOLI provides comprehensive details about OFLA, including eligibility, leave types, employer obligations, and employee rights.
 - Website: <https://www.oregon.gov/boli/workers/Pages/oregon-family-leave.aspx>

LEAVE TO DONATE BONE MARROW

Eligibility

Employees working 20 or more hours per week are eligible for this leave.

Length of Leave

An employee may use up to 40 hours of leave which may be taken as paid or unpaid time. In extenuating circumstances, approval to take more time off [paid or unpaid] may be granted by a supervisor or manager.

Request Procedure

Employees must notify their manager or supervisor as soon as practicable after becoming aware that they will be donating bone marrow. They are expected to provide a copy of the doctor's verification for the bone marrow donation. If a medical determination is made that the employee does not qualify as a bone marrow donor, the paid leave of absence used before that determination will not be affected.

Status of Benefits

Benefits are not affected by this leave.

PERSONAL LEAVE OF ABSENCE

Full-time, regular employees may be granted an unpaid personal leave of absence under certain circumstances. A personal leave of absence is an approved period of time away from work for personal reasons that do not fall under the guidelines of the Oregon Family and Medical Leave Policy or any other leave policy. A personal leave of absence is granted at the Port's discretion and is normally granted to protect the length of service and benefit rights of an employee whose service might otherwise be terminated.

Eligibility:

If OFLA does not apply to an employee's situation, employees become eligible for a personal leave of absence after 90 days of service, provided all earned paid leave has been exhausted first. Arrangements for a personal leave of absence must be made with the employee's supervisor and approved by the Executive Director.

Length of Leave:

The leave may be requested for any time over 5 consecutive days. A personal leave of absence starts on the first regular workday following the last day worked. The maximum leave allowed under this policy is 90 days, unless a different timeline is approved in writing by the Executive Director. In situations involving a qualifying disability, unpaid leave beyond 90 days may be granted in compliance with applicable laws, including reasonable accommodations under the Americans with Disabilities Act (ADA) and similar regulations.

Request Procedure:

An employee is required to provide the employer notice of the intention to take leave. For planned events the employee is required to provide thirty 30 days written notice. For unplanned events the employee is required to notify the employer within twenty-four (24) hours of the leave and provide written notice within three (3) days. If an employee is incapacitated due to an unplanned event and are unable to meet these obligations, we ask the employee to notify the employer as soon as possible. Leave requests must include an expected date of return. If the employee does not return within three days of that date and no extension has been requested, it will be assumed that the employee has resigned.

Pay While on Leave:

Personal leaves of absence are without pay. Employees must use accrued PTO leave during a personal leave of absence. After this is exhausted, the leave is unpaid.

Status of Benefits:

The Port will pay its share of medical benefits until the maximum leave days are reached. Employees must pay their share of premiums by the due date to maintain coverage. After 90 days, insurance coverage will not be maintained unless employees pay the full premium monthly. Benefits do not accrue during personal leave but are retained at the same level.

Reinstatement:

The Port will attempt to arrange employment for individuals returning from a personal leave of absence, but no guarantees are made unless approved in writing by the Executive Director. While on a personal leave of absence, employees are required to check in with their supervisor on a regular basis as agreed upon to inform the Port of their status and to notify of any change in personal data. Employees may be required to present a doctor's release before being reinstated if the leave was medically related.

MILITARY LEAVE

Employees who wish to serve in the military and take military leave should contact the Human Resources delegate for information about their rights before and after such leave. Employees are entitled to reinstatement upon completion of military service, provided they return or apply for reinstatement within the time allowed by law.

All employees who are members of the National Guard, National Guard Reserve, or any reserve component of the Armed Forces of the United States or the United States Public Health Service are entitled to a paid leave of absence from duties for a period not exceeding 21 workdays in any federal fiscal year (October 1st through September 30th) for training, provided they have been employed for at least six months prior to the leave. Employees who have not worked for the Port for six months will also receive up to 21 workdays in any federal fiscal year for the same purposes, but such leave will be unpaid. Employees are not required to take their leave in one block of time but may use the paid leave allowed under this rule over the course of the federal fiscal year. The actual number of paid work hours allowed is dependent on the employee's standard work schedule but must be consistent with the intent of this rule. Military leave may be used for active duty or inactive duty for training, state active duty, and duty under Title 10 or 32 of the United States Code.

The total number of paid days for both training and active duty shall not exceed the total amount allowed above in any federal fiscal year. Absences incurred for additional active duty or inactive duty for training, state active

duty, or duty under Title 10 or 32 of the United States Code may be charged to accrued paid time off, such as PTO or compensatory time, or taken as unpaid leave.

Request Procedure:

Employees must provide oral or written notice, using the Leave of Absence Request Form⁸, of their obligation or intention to perform service in the uniformed services. Notice must be given unless precluded by military necessity or if it is otherwise unreasonable or impossible. Failure to provide notice may result in loss of re-employment rights.

Status of Benefits:

Reservists, National Guard members, and veterans returning from military service in the Armed Forces retain rights with respect to seniority, vacation, compensation, and length of service pay increases, as provided by applicable statutes of the United States and the State of Oregon. For any leave extending beyond 30 days, employees may maintain health care insurance benefits for up to 24 months while on leave by paying the full insurance premiums.

PAID LEAVE OREGON

Paid Leave Oregon (PLO) is a state-run program, administered by the Oregon Employment Department (OED), that allows eligible employees to take up to 12-weeks of paid time off per benefit year, for the following reasons:

- **Family leave** – for an employee to care for an eligible family member with a serious illness or injury, to bond with a new child after birth, adoption, or foster care placement, or to effectuate the legal process required for placement of a foster child or the adoption of a child. (eff 1/1/25)
- **Medical leave** – for an employee experiencing their own serious health condition or disability due to pregnancy.
- **Safe leave** – for an employee or eligible child dependent experiencing issues related to sexual assault, domestic violence, harassment, bias, or stalking.

The Paid Leave program also allows employees to take an additional two (2) weeks of Paid Leave for pregnancy, childbirth, or related medical conditions.

Notification Requirements

Although the Paid Leave Oregon program is administered by the Oregon Employment Department (OED), employees are required to notify the Port when they have applied for leave.

Foreseeable Leave: If the need for Paid Leave is foreseeable or planned, the employee is required to provide the Human Resource delegate with at least 30 days' written notice before paid leave begins.

Unforeseeable: If the need for Paid Leave is unforeseeable or unplanned, an employee is required to provide oral notice to their supervisor within 24 hours of the start of the leave, and the employee must also provide written notice within three (3) days after the start of the leave.

Written notice must include the employee's first and last name, type of leave, explanation of the need for leave, and anticipated timing and duration of leave. Timing and duration of leave should include the employee's plan for taking leave on an intermittent basis (and the proposed schedule) or in one block of time.

If the employee's dates of scheduled leave change, are extended by the PLO program, or if the reason for leave becomes known and/or, if circumstances change during the leave and the leave period differs from the employee's original notice, the employee must notify the Human Resource delegate within three business days,

⁸ R:\Archives\Administrative Records\Templates & Forms\Human Resources\Absence Leave Request

or as soon as possible. Regardless of the reason for leave, or whether the need for leave is foreseeable, employees are expected to comply with Port's normal call-in procedures.

Under Oregon law, an employee who fails to follow these notification requirements may receive reduced PLO benefits; specifically, the first weekly benefit amount will be reduced by 25 percent (the penalty calculated for leaves that are taken in increments of less than a full work week differs). See OAR 471-070-1310(9) and (10).

Accrued Leave and Holiday Pay While on Leave

Employees using accrued leave in addition to receiving PLO benefits will continue to accrue pro-rated PTO or other employer-provided leave, and receive holiday pay. For example, if PLO pays an employee 60% of their salary that employee can use their leave bank for the other 40% and will accrue PTO, and holiday pay at a rate of 40%. Employees who do not use accrued leave while on Paid Leave will not accrue PTO, or other employer-provided leave, and will not receive holiday pay.

Benefits While on Leave

If an employee is receiving Paid Leave benefits, the Port will continue the employee's healthcare, life, disability, and all eligible voluntary coverage, on the same terms as if the employee had continued to work. An employee wishing to maintain coverage when on Paid Leave is responsible for paying their share of premiums, the same as when premiums were paid by the employee, prior to receiving Paid Leave benefits. If the Port chooses to pay the employee's portion of the insurance coverage during the period of Paid Leave, employees are expected to repay the Port for those premiums. Upon return to work, the Port will deduct those premiums from an employee's pay, up to 10% of an employee's gross pay, each period, until the Port has been paid back. If an employee cannot or will not pay their share of premiums, the Port may discontinue coverage until the employee returns from leave. Additionally, if an employee fails to return to work from leave under PLO, then the Port may use any legal means available to collect any amount the employee owes to the Port for covering the employee's share of the premiums while the employee was on leave under PLO.

Medical Certification Prior to Returning to Work

If an employee uses more than three consecutive scheduled workdays for their own serious health condition, prior to returning to work the Port may ask for a medical certification from their healthcare provider stating that the employee is able to resume work.

Job Protection

Employees who worked for the Port for more than 90 consecutive calendar days prior to taking Paid Leave may be reinstated to their former position if the position still exists. If the position has been eliminated, the employee may be restored to a similar position with similar job duties with the same employment benefits and pay. Reinstatement is not guaranteed if the position has been eliminated under circumstances where the law does not require reinstatement. Employees are expected to promptly return to work when the circumstances requiring Paid Leave have been resolved. If an employee does not return to work at the end of their Paid Leave, reinstatement may not be available.

Use of Accrued Leave During Paid Leave

PLO benefits may not provide employees with 100% of their gross regular wages. Employees receiving PLO benefits may choose to use accrued paid leave (paid time off, etc.), and/or comp time in addition to receiving PLO benefits up to full wage replacement while on PLO. Accrued paid leave must be used in the following order: PTO, comp time, floating holiday, etc.

Complaint Procedure

The Port prohibits retaliation against an employee with respect to hiring or any other term or condition of employment because the employee asked about, requested, or used Paid Leave.

Who to Contact for More Information

For more information or questions about the Paid Leave Oregon (PLO) policy, employees should contact the Human Resource delegate. For questions regarding PLO, they should contact the State Employment Department. Additional information about the PLO program, including steps for applying for PLO benefits and contact details,

can be found at <https://paidleave.oregon.gov/>. A poster with Paid Leave Oregon information, including instructions on how to apply for benefits, is located in the food prep room, the Maintenance Shop, and the Toll Booth

Cost:

Employees will see a .006% deduction from gross wages for each paycheck. The employer will contribute .004% of the employee's gross wages for each paycheck. The employee and employer minimum and maximum, as well as overall costs, of this coverage will be assessed annually by the Oregon Employment Department and may change. The Port will provide notice to employees in advance of any change.

Filing a Claim for coverage:

Employees will need to establish an account at Frances Online: <https://frances.oregon.gov/> and file claims electronically. This is the electronic system of record for the Oregon Employment Department. Employees are responsible for submitting the required paperwork and any updates or changes to their claim. The employer will be unable to complete the application process on the employee's behalf.

PAID LEAVE DONATION PROGRAM

Eligibility for Paid Leave Donation:

Port employees who have exhausted all their paid leave benefits may be eligible to receive a donation of paid leave from other Port employees when extended time off is required due to illness or injury.

Port's Role in Paid Leave Donation:

In such events, the Port's role will be limited to crediting the paid leave balance of the receiving employee with the amount donated by another employee who has a sufficient paid leave balance to make the donation. Employees are permitted to donate up to 25% of their paid leave balance.

Process for Donating Paid Leave:

1. Completion of PLDP Form: A Port employee wishing to donate paid leave under the Paid Leave Donation Program (PLDP) must complete a PLDP⁹ form.
2. Submission to HR delegate: The completed form must be submitted to the Human Resources delegate.
3. Form Details: The PLDP form must include the name of the employee to whom the sick leave is being credited, the nature of the eligible event, and the number of hours of the donor's paid leave being transferred.
4. Multiple Applications: An employee may submit multiple applications for any qualifying eligible event as defined.

Finance Department's Responsibility:

The Finance Department will be responsible for calculating the appropriate amount of donated leave to ensure that the financial compensation is equivalent between the donating employee and the receiving employee.

This policy ensures fair and equitable management of the Paid Leave Donation Program while providing necessary support to employees in need.

⁹ R:\Archives\Administrative Records\Templates & Forms\Human Resources\Paid Leave Donation Program Form

HEALTH AND SAFETY

The Port is committed to and legally responsible for providing employees with a safe and healthy work environment, whether on-site, in the field, or at an approved alternative location (such as an employee's home). To achieve this goal, both management and employees are expected to make diligent efforts to promote safety in accordance with applicable laws and standards.

Safety Rules and Regulations Development

The Port develops and implements safety rules and regulations through its managers and supervisors. This process is ongoing and includes periodic safety audits to assess the necessity and feasibility of providing devices or safeguards to ensure a safe and healthful workplace. Additionally, employees are educated about workplace hazards and the proper and safe methods to use when performing job tasks.

Employee Responsibilities

Employees are expected to:

- Give full skill and attention to their duties, using the highest standard of care and good judgment.
- Follow safety rules and regulations at all times, including using appropriate protective clothing, shoes, and equipment.
- Attend all training sessions offered.
- Adhere to the directions of warning signs, signals, and supervisory personnel.

Reporting Injuries and Illnesses

All job-related injuries or illnesses must be reported to a supervisor immediately, regardless of severity. In the case of a serious injury, the reporting obligation is deferred until circumstances reasonably permit a report to be made.

Safety Rules and Regulations Communication

Safety rules and regulations will be issued or modified as necessary and will become effective immediately upon communication. These rules and regulations will be distributed to employees and posted on the employee bulletin board.

Smoking and Tobacco Use in the Workplace

The Port is a non-smoking facility, including all Port buildings and vehicles. This policy also covers the use of electronic cigarettes, vaping devices, and other tobacco products such as cigars, pipes, and smokeless tobacco. Areas outside the office may be designated as smoking areas, and smoking or the use of other tobacco products is limited to these areas. Employees are not permitted to smoke, vape, or use any tobacco products within 10 feet of any entrance, exit, window, or air intake device. Any employee with concerns about the designated areas should address them with the appropriate supervisor.

SUBSTANCE ABUSE AND ALCOHOL

The Port is committed to providing a workplace free from substance abuse. To ensure the safety of employees, service users, and the public, it is the policy of The Port to maintain a work environment free from the effects of drugs, alcohol, or other impairing substances.

Prohibited Conduct

The following activities are prohibited on Port premises, property, during work time, or while representing The Port. Violations may result in corrective action, up to and including termination:

- **Alcohol:** Possession, transfer, use, or being under the influence of alcohol while on Port property, during work time, while operating Port vehicles (or personal vehicles used for Port business), or in other circumstances that adversely affect Port operations or the safety of employees or others.
 - The consumption of any intoxicating liquor within four hours of reporting to work or during rest breaks or meal periods is prohibited. An employee will be considered "under the influence" if physical or mental faculties are affected to any perceptible degree, or if blood alcohol content exceeds 0.02 percent while at work.
- **Controlled Substances:** Possession, distribution, use, manufacture, or being under the influence of any narcotic, hallucinogen, stimulant, sedative, or any controlled substance while on Port property, during work time, or while operating Port vehicles (or personal vehicles used for Port business). This includes legal substances such as marijuana, which remain prohibited for use while on duty.
 - Any use of controlled substances prior to reporting to work or during rest breaks that impairs physical or mental faculties to any perceptible degree is prohibited. A positive test result for controlled substances will be considered a violation of this policy.
 - **Note:** "Controlled substances" include those listed in Schedules I-V of the Federal Controlled Substances Act, including marijuana, even if its use is lawful under state law.

Bringing to Port property, or possessing, items or objects on Port property that contain any "controlled substance," including, for example, "pot brownies," "edibles," and candy containing marijuana. No employee, regardless of position held, may knowingly serve items containing marijuana or any other "controlled substance" to coworkers, members of the public, or elected officials while on work time or on/in Port property.

- **Drug Paraphernalia:** Possession of devices marketed for or designed specifically for ingesting or inhaling controlled substances (e.g., pipes, bongs, vape pens) is prohibited on Port property.

Prescription and Over-the-Counter Drugs

Employees who are using prescription or over-the-counter drugs that may affect their ability to perform their duties safely must inform their supervisor.

- The use of prescription or over-the-counter drugs is not prohibited by this policy. However, if such use impairs job performance or safety, The Port may reassign the employee or take other appropriate actions. Failure to report the use of medication that may affect performance will result in disciplinary action.
- The use of medical marijuana is prohibited in the workplace, even if it is authorized under state law. Employees who use medical marijuana for a disability should discuss alternative accommodations with their supervisor, as The Port does not permit marijuana use as an accommodation.

Testing for Substance Use

The Port reserves the right to conduct drug and alcohol testing under the following circumstances:

- **Pre-Employment Testing:** Applicants who receive a conditional offer for safety-sensitive positions may be required to undergo drug and alcohol testing.
- **Reasonable Cause Testing:** Employees suspected of being under the influence of drugs or alcohol during work hours or in violation of this policy may be required to undergo testing.
- **Post-Accident Testing:** Employees may be tested following an accident that results in significant property damage or injury, or where drug or alcohol use is suspected.

- Random Testing: For employees in safety-sensitive positions, random testing may be conducted to ensure compliance with this policy.

Reasonable Cause Testing

"Reasonable cause" is defined as an articulable belief based on specific facts and reasonable inferences drawn from those facts that an employee may be under the influence of drugs or alcohol. Indicators include:

- Direct observation of drug or alcohol use;
- Physical symptoms of impairment (e.g., glassy eyes, slurred speech, poor coordination);
- Erratic or abnormal behavior;
- Significant deterioration in job performance;
- Unexplained absenteeism or tardiness.

Supervisors should document the facts leading to reasonable cause and forward the report to the Executive Director for approval prior to testing. A second witness should corroborate the findings when possible.

Drug Testing Procedure

If an employee's initial laboratory screening test for controlled substances yields a positive result, the following process will be followed:

- **Second Test:** A second test shall be performed using a portion of the same sample withdrawn from the employee during the initial screening.
- **Notification:** If the second test confirms the positive result, the employee shall be notified in writing by the Human Resources delegate. The notification will include the specific substance identified in the test.
- **Third Test Option:** The employee has the right to request a third test of the same sample within 24 hours of receiving the letter of notification. However, the cost of this third test will be borne by the employee.

Refusal to Test or Cooperate

An employee who refuses to submit to a required drug or alcohol test when there is reasonable cause will be subject to disciplinary action, up to and including termination. Refusal to cooperate includes:

- Failing to provide a sample when requested;
- Tampering with or attempting to tamper with a specimen sample;
- Using chemicals or other substances to mask or otherwise alter the presence of drugs or alcohol in the specimen;
- Providing a sample that was produced by someone or something other than the employee.

The reasons for refusing to test will be taken into consideration when determining the appropriate disciplinary action.

Search of Property

When there is reasonable cause to believe that an employee possesses alcohol or a controlled substance on Port property or has otherwise violated the provisions of this policy regarding possession, sale, or use of controlled substances or alcohol, The Port reserves the right to search any property provided by The Port to the employee. This includes, but is not limited to:

- Clothing provided by The Port (e.g., uniforms);
- Lockers, toolboxes, or desks;
- Port-owned vehicles or equipment.

Employees should have no expectation of privacy in any property, equipment, or supplies provided by The Port.

Last-Chance Agreement

In certain situations, The Port may offer an employee who has violated this policy the opportunity to enter into a Last-Chance Agreement in lieu of termination. A Last-Chance Agreement is a formal document outlining the terms and conditions under which the employee may continue employment while addressing substance abuse issues. Key provisions typically include:

- **Mandatory treatment:** The employee may be required to undergo and complete a substance abuse treatment or rehabilitation program.
- **Ongoing compliance:** The employee must comply with all Port policies, including refraining from further substance use or policy violations.
- **Follow-up testing:** The employee may be required to undergo random drug and alcohol tests at the discretion of The Port.
- **Specific performance expectations:** The employee must meet outlined performance expectations during the agreement period.

Failure to comply with the terms of a Last-Chance Agreement will result in immediate termination, regardless of the provisions of any other personnel policies.

Consequences of Positive Test Results or Policy Violations

An employee who violates this policy or tests positive for controlled substances or alcohol may be subject to corrective action, up to and including termination. Alternatively, an employee may be offered a Last-Chance Agreement, as defined above. Failure to comply with the terms of a Last-Chance Agreement will result in immediate termination.

Confidentiality

All information related to drug and alcohol testing, as well as test results, is confidential. Access to such information is limited to those with a legitimate need to know, and any disclosure requires written consent from the employee.

Employee Assistance

The Port encourages employees with substance abuse issues to seek assistance before performance or safety becomes a concern. Employees may contact their supervisor or the Human Resources department for help in obtaining treatment. However, seeking assistance will not prevent disciplinary action if policy violations have occurred.

WORKPLACE SAFETY

Commitment to Safety

The Port recognizes the importance of a safe workplace for employees. A safe and comfortable work environment enhances employee satisfaction and productivity. The best source for official OSHA rules on workplace safety is the Occupational Safety and Health Administration's (OSHA) website at <https://www.osha.gov/laws-regs>.

Prohibition of Weapons

To ensure workplace safety, the Port specifically prohibits any employee, from bringing any kind of weapon, knife (other than a folding pocketknife), or firearm including hunting rifles onto the premises. If there is any uncertainty about whether an item is considered a weapon under this policy, employees must ask their supervisor before bringing the item onto Port property, which includes personal vehicles parked in designated parking areas.

Reporting Safety Risks

Despite our best efforts to prevent them, situations may arise that pose a risk of harm to employees and others. All employees are obligated to report any incidents that pose such risks or threaten the safety, security, or financial interests of the Port. Reports should be made directly to the employee's supervisor or manager. All

information related to these reports, including the identity of the reporting employee, will be kept as confidential as possible. Generally, the reporting employee will be notified of the actions taken in response to the report. Further details can be found in the Workplace Violence section of this handbook.

Conducting Investigations

The Port, out of business necessity, may conduct an investigation of a current employee when behavior raises concerns about work performance, reliability, honesty, or potential threats to safety. Investigations may include reviewing criminal records and searching the Port's property, such as desks, work areas, lockers, file cabinets, voicemail systems, and computer systems.

Familiarization with Security Systems

All employees should familiarize themselves with the Port's security systems, including the locations of panic buttons and surveillance cameras, key check-out/check-in procedures, and the duties and responsibilities of security patrol officers.

Corrective Action

Employees found to have violated any part of this policy may face corrective action, up to and including termination.

Search of Property: Port and Private

For the safety of employees and the welfare of the Port, authorized personnel may search and inspect both Port property and personal items brought onto Port property, including owned or leased facilities, surrounding grounds, and parking areas. Refusal to cooperate in a search, inspection, or investigation will result in disciplinary action, up to and including termination.

Eligible Items for Search

Port property eligible for search includes but is not limited to individual lockers, desks, filing cabinets, and computers. Personal property brought onto Port grounds eligible for search includes but is not limited to pockets, purses/wallets, briefcases, cars/trucks, lunch boxes, toolboxes, shopping bags/boxes, and coats which may be searched with reasonable suspicion. Employees should have no reasonable expectation of privacy regarding Port premises and any property brought or stored thereupon.

Search Procedure

The decision to search will involve the Executive Director, Finance Director, or department manager. The Executive Director or Finance Director will determine the reasonableness of a search or inspection and whether reasonable suspicion exists to search any personal property stored on Port property. Whenever possible, a minimum of three personnel will conduct the search: two to conduct the search and one to document and record the inventory and event. One observer must be of the same gender as the person whose belongings are being searched.

Documentation of Search

Documentation will include the following:

- Reason for the search (observed events, seriousness of the offense, reliability of the source)
- Individuals involved
- Location of the search
- Date and time of the search
- Findings, if any
- Actions taken with the person involved
- Final instructions given to the employee

The Executive Director or Finance Director will immediately report any illegal items found to the appropriate authorities and document such notification.

EMERGENCY RESPONSE

Emergency Situations

The Port may face major disruptions due to occurrences beyond its control. Employees are expected to exercise good judgment in responding to these events as the situation necessitates. The Port will strive to provide emergency and limited services during such disruptions. Decisions regarding closure, suspension of activities, or making the Port available for community support will be made by the Executive Director.

Employee Compensation During Emergencies

Compensation for employees will be determined in accordance with all applicable regulations when individual facilities or activities are closed due to emergency conditions. Employees who are not compensated during an emergency-related closure may use available paid leave.

Reporting Threats

Any threats to Port property or employees must be reported immediately to a supervisor, the Human Resources delegate, or the Executive Director.

Fires and Emergencies

IN CASE OF EMERGENCY, DIAL 911. Exits, fire extinguishers, and first aid kits are located throughout the Port office buildings. An Automated External Defibrillator (AED) unit is located in the kitchen. Volunteers trained in CPR, AED, and first aid are available. Exits and areas around fire extinguishers must remain clear at all times.

Accidents

All workplace injuries or accidents, no matter how insignificant they may seem, must be reported to a supervisor immediately, and an appropriate accident report must be completed. In the event of a time-loss accident or an accident requiring medical treatment, the Executive Director must be notified immediately. Employees who fail to report an injury or accident as required will be subject to corrective action, up to and including termination.

Safety Program

Safety rules are detailed in the adopted Emergency Action Plan¹⁰. Employees are responsible for familiarizing themselves with these rules and observing them at all times. Upon hire, each employee will undergo a Safety Orientation that provides information and training on all safety-related issues for their position.

¹⁰ R:\Archives\Policy Documents\Policies & Procedures\Safety\Emergency Action Plan

EMPLOYMENT SEPARATION

Types of Separation

Separation from employment with the Port occurs when an employee voluntarily resigns, is laid off, or is discharged by the Port.

At-Will Employment

Employees of the Port are engaged in an 'at-will' employment relationship. This means that either the employee or the Port may terminate employment at any time, with or without reason or notice. All grievance and dispute resolution policies are subordinate to the at-will employment policy.

Resignation

Resignation is a voluntary act by an employee to terminate employment with the Port. Employees are expected to provide as much notice as possible, preferably a minimum of two weeks. This process includes returning Port property, completing required forms, and participating in an exit interview. All Port property, including phones, computers, credit cards, keys, manuals, vehicles, tools, and equipment, must be returned to the direct supervisor or the Human Resources delegate on or before the last day of work. Employees who miss three or more consecutive workdays without contact are typically considered to have voluntarily resigned.

Job Abandonment

Employees are expected to be reliable in reporting for scheduled work. Absenteeism and tardiness disrupt operations and may lead to corrective action, up to and including termination. If an employee fails to call in or show up for work for three consecutive shifts or days, job abandonment and voluntary resignation will be assumed.

Job Elimination and Reduction in Work Hours

While the Port aims to avoid reducing hours or staff, situations may arise where such measures are necessary. Responses may include offering voluntary reductions in hours, reducing work hours, reducing the workforce, or implementing other cost-saving measures. Factors considered in selecting employees for reduced hours or layoff include:

- Department, location, or job
- Job knowledge, skills, and ability to perform required work
- Performance, attendance, safety, and corrective action records
- Required licenses, registrations, and certifications
- Creativity and teamwork skills
- Demonstrated willingness to go the extra mile for the Port

Evaluation of these factors is at the discretion of the Port. When factors are substantially equal, employees with the shortest term of service will be laid off first. A supervisor or manager will personally notify employees of a layoff, provide a letter detailing the conditions of the layoff, and explain effects on benefits, reemployment possibilities, and outplacement services. Limited reemployment rights may be provided for a specified period. The order of recall will be determined using the above factors. An offer of reemployment may be made orally or in writing. Failure to respond to an offer may result in waiving reemployment privileges.

Termination

The Port's general practice is to provide employees who have completed the initial introductory period with an opportunity to correct minor performance and conduct problems before termination. The corrective action policy in this Handbook describes actions management may take to address performance infractions. The decision to terminate is based on the seriousness of the infraction, overall performance record, and length of service.

Employees have the opportunity to be heard in matters involving corrective action through the formal dispute resolution procedure in this Handbook.

Exit Interview

An exit interview should be conducted with all employees who are terminating their employment, including those resigning, retiring, or being terminated. The purposes of the interview include securing forwarding addresses, reviewing final hours accrued, completing retirement and insurance forms, and explaining the final paycheck. The interview may also include a discussion of the reasons for leaving. The Executive Director, department supervisor, or the Human Resources delegate will conduct the exit interview. All pay and benefits shall cease as of the termination date, except as provided by COBRA. The final check will include all eligible accrued leaves payable at termination.

Return of Port Property

Upon termination, the supervisor is responsible for ensuring the return of all keys, tools, equipment, computers, radios, phones, and other Port property used by or in possession of the terminated employee.



Port of
HOOD RIVER

Handbook Receipt Acknowledgment Form

As an employee of the Port of Hood River ("Port"), I acknowledge the following:

I have been provided with a copy of the Employee Handbook. I understand that the Handbook contains important information about Port's policies, work rules, and my benefits. I have both read and understood the information in the Handbook and have asked a supervisor/manager for the clarification of any information I did not understand.

I acknowledge the Handbook is neither a contract of employment nor a guarantee of specific treatment in any situation; that the Port has the right to change, modify, add to, substitute, eliminate, interpret, and apply, in its sole judgment, the policies, rules, and benefits described in this Handbook; and that the current Handbook supersedes all prior handbooks, policies, and understandings related to the subjects it contains.

Only authorized personnel, specifically the Human Resources delegate or the Executive Director, are permitted to make changes to this Employee Handbook. All amendments must be put in writing and require approval by the Port Commission to be deemed valid. Once approved, any changes to the content of this handbook will be communicated to employees through official notices.

I understand that, unless stated otherwise in an employment contract, my employment relationship with the Port is "at-will" and either the Port or I can end the relationship at any time, with or without reason or notice. The Executive Director is the only person who has the authority to enter into an employment contract, which must be in writing and signed by both parties to be valid.

Lastly, I am aware that I may be given confidential information during my employment, including customer lists, proprietary Port plans, and other information. I understand this information is critical to the success of the Port and I agree not to disseminate or use it outside of the Port, even in the event of my separation, either voluntary or involuntary.

I also acknowledge that before signing this form, I asked for and received clarification on any of the items discussed above that I did not understand.

Employee Signature

Date

Print Employee's Name

Prepared by: Kevin Greenwood
Date: October 15, 2024
Re: Real Estate Services Procurement



BACKGROUND:

On September 17, 2024, the Commission directed staff to begin a Real Estate Leasing/Sales Personal Services procurement process. This individual would help the Commission with various real estate needs.

An evaluation committee reviewed, scored proposals and conducted interviews with four realtors. In a very close ranking, the committee recommended Tom Bacci, Kidder Mathews, for the contract. The final score summary was as follows: 141, 137, 130 and 129.

The evaluation committee recommends contracting with Tom Bacci, Kidder Mathews, to establish a Master Listing Agreement (MLA) with the Port of Hood River. Mr. Bacci is currently a Senior Vice President at Kidder Mathews, a position he has held since 2015. In prior roles, he served as a Senior Vice President at Voit Real Estate Services from 2012 to 2015, and a Senior Vice President at Grubb & Ellis from 1990 to 2012. Throughout his 34-year commercial real estate career, Mr. Bacci has primarily focused on office leasing and sales. His clients include Sacramento County, Hewlett Packard, and Adventist Health. The committee is recommending this candidate based on his sales acumen and expertise in commercial real estate marketing, pricing, and strategic planning.

Staff is looking for direction from the Commission to enter into negotiations with Mr. Bacci for a master services agreement and at least two work orders which would be negotiated and brought back to the Port Commission in a special meeting, possibly Oct. 22nd.

The schedule shows a new contract starting November 1, which would require a special meeting of the Commission to approve the contract.

ISSUE:

The Port has several real estate issues that require a real estate professional:

- Evaluating marketing rates
- Leasing vacant spaces
- Selling the Big 7 Building
- Evaluating storage unit rates
- Evaluating potential spaces in Hood River to lease during bridge construction for relocation of administrative offices.

RECOMMENDATION:

Following through on the procurement process approved in September, staff is recommending that the Commission authorize starting negotiations with Tom Bacci, Kidder Mathews, for real estate services.

FISCAL IMPACT:

Since payment for services are a function of sales price/rental rates, there would be no negative net impact to the Port's bottom line. The Port does need to identify the expenditure, however. Since a prior employment position was budgeted, but not filled, there will be savings to the Personal Services expenditure category. Real estate commissions would show as an expenditure to the Materials & Service category and reconciled at year end.

SUGGESTED MOTION:

MOTION to authorize entering into negotiations with Tom Bacci, Kidder Mathews, on a master services agreement and work orders.

ALTERNATIVES:

No alternatives are proposed or recommended.

ATTACHMENTS:

none



Prepared by: Debbie Smith-Wagar, Finance Director
Date: October 15, 2024
Re: 501(c)(3) Formation

At the May 23, 2024 meeting the commissioners discussed the possibility of starting a non-profit organization to get donations and apply for grants for various Port activities, such as the airport and parks. Here is some additional information on the process.

The first step in forming a 501(c)(3) is to prepare draft by-laws that are filed with the state. The draft by-laws are included with this memo.

If approved, the by-laws will be filed with the State, along with a form to incorporate. The fee for incorporation is \$50.

Once the entity is formed under state law, then the Port can apply for tax exempt status with the IRS. This involves filing a form and paying the associated fee (\$550). The Port will receive a determination letter that will confirm the entity's tax-exempt status. The Port will also need to apply for a federal employer identification number (even though the entity will not have employees – the federal number is still required). That is a standard form and does not have a fee associated with it.

At its first meeting the entity will need to officially adopt the by-laws

Once the entity is formed there are on-going fees. The entity will be required to keep a set of accounting records separate from the Port. Most local governments that have foundations set up a QuickBooks-type file for tracking bank accounts, revenues and expenses. The entity will also need an annual audit, and it will have to file an annual tax return called a Form 990. Port staff can facilitate the audit in conjunction with the Port's annual audit, and Port staff can fill out and file the Form 990, assuming donations are not complex.

Recommendation: MOTION to approve Resolution No. 2024-25-9 to form a 501(c)3 corporation.

This page intentionally left blank.

PORT OF HOOD RIVER
Resolution No. 2024-25-9

A RESOLUTION TO FORM A 501(C)3 CORPORATION

WHEREAS, the Port of Hood River desires to pursue grants and other donations that may only be available to not-for-profit organizations; AND

WHEREAS, formation of a 501(c)3 charitable organization will provide transparency when receiving donations for a specific purpose; AND

WHEREAS, the Commission has reviewed the by-laws for the new organization as presented as an attachment to this resolution; NOW THEREFORE

THE PORT OF HOOD RIVER BOARD OF COMMISSIONERS RESOLVES AS FOLLOWS:

Section 1. The Port of Hood River authorizes the formation of a 501(c)3 to be called *Port of Hood River Foundation*.

Section 2. The purpose of this foundation is to support the Port of Hood River in charitable, educational, and scientific endeavors.

Adopted by the Board of Commissioners of the Port of Hood River this 15th day of October 2024.

SIGNED

Kristi Chapman, President

ATTEST

Michael Fox, Secretary

Article I. Name

The name of this Corporation is Port of Hood River Foundation.

Article II. Principal Office

The registered office for the transaction of the business of this Corporation shall be located in the state of Oregon. The Board of Directors may, at any time, change the location of the registered office within Oregon. This Corporation may also have offices at more than one place in Oregon.

Article III. Purpose

This Corporation shall be organized and operated exclusively for charitable purposes. Subject to the limitations stated in the Articles of Incorporation, the purposes of this Corporation shall be to engage in any lawful activities, none of which is for profit, for which corporations may be organized under Chapter 65 of the Oregon Revised Statutes (or its corresponding future provisions) and Section 501(c)(3) of the Internal Revenue Code of 1954 (or its corresponding future provisions). This Corporation shall hold its primary purposes to be charitable, educational and scientific purposes of a 501(c)(3), including to support the governmental property of Hood River.

Article IV. Membership

The membership of the corporation shall consist of the members of the Board of Directors.

Article V. Board of Directors

Section 1. General Powers

The affairs of the Corporation shall be managed by its Board of Directors. The Board of Directors shall have control of and be responsible for the management of the affairs and property of the Corporation. The Board of Directors shall appoint the Executive Director.

Section 2. Number, Tenure, Requirements, and Qualifications

- a. The number of Directors shall be fixed from time-to-time by the Directors but shall consist of no less than three (3) nor more than seven (7) including the following officers: the President, the Vice-President, the Secretary, and the Treasurer.
- b. The members of the Board of Directors shall, upon election, immediately enter upon the performance of their duties and shall continue in office until their successors shall be duly elected and qualified. All members of the Board of Directors must be approved by a majority vote of the members present and voting. No vote on new members of the Board of Directors shall be held unless a quorum of the Board of Directors is present as provided in Section 6 of this Article.

- c. Members of the Board of Directors shall serve four year terms. Their terms shall be staggered so that at the time of each annual meeting, the terms of approximately one-third (1/3) of all members of the Board of Directors shall expire. For the initial term, 1/3 of the Board of Directors will serve for a 1 year term, 1/3 of the Board of Directors will serve for a 2 year term and the remaining Board of Directors will serve for a 3 year term to ensure the terms are staggered.
- d. Each member of the Board of Directors shall attend at least three meetings of the Board per year.

Section 3. Regular and Annual Meetings

An annual meeting of the Board of Directors shall be held at a time and day in the month of April of each calendar year and at a location designated by the Executive Committee of the Board of Directors. The Board of Directors may provide by resolution the time and place, for the holding of regular meetings of the Board. Notice of these meetings shall be sent to all members of the Board of Directors no less than ten (10) days, prior to the meeting date.

Section 4. Special Meetings

Special meetings of the Board of Directors may be called by or at the request of the President or any two members of the Board of Directors. The person or persons authorized to call special meetings of the Board of Directors may fix any location, as the place for holding any special meeting of the Board called by them.

Section 5. Notice

Notice of any special meeting of the Board of Directors shall be given at least two (2) days in advance of the meeting by telephone, facsimile or electronic methods or by written notice. Any Director may waive notice of any meeting. The attendance of a Director at any meeting shall constitute a waiver of notice of such meeting, except where a Director attends a meeting for the express purpose of objecting to the transaction of any business because the meeting is not lawfully called or convened. Neither the business to be transacted at, nor the purpose of, any regular meeting of the Board of Directors need be specified in the notice or waiver of notice of such meeting, unless specifically required by law or by these by-laws.

Section 6. Quorum

The presence, in person of a majority of current members of the Board of Directors shall be necessary at any meeting to constitute a quorum to transact business, but a lesser number shall have power to adjourn to a specified later date without notice. The act of a majority of the members of the Board of Directors present at a meeting at which a quorum is present shall be the act of the Board of Directors, unless the act of a greater number is required by law or by these by-laws.

Section 7. Vacancies

Whenever any vacancy occurs in the Board of Directors it shall be filled without undue delay by a majority vote of the remaining members of the Board of Directors at a regular meeting.

Vacancies may be created and filled according to specific methods approved by the Board of Directors.

Section 8. Compensation

Members of the Board of Directors shall not receive any compensation for their services as Directors.

Section 9. Removal

Any member of the Board of Directors may be removed with or without cause, at any time, by vote of two-thirds (2/3) of the members of the Board of Directors if in their judgment the best interest of the Corporation would be served thereby. Each member of the Board of Directors must receive written notice of the proposed removal at least ten (10) days in advance of the proposed action. An officer who has been removed as a member of the Board of Directors shall automatically be removed from office.

Article VI. Officers

Section 1. Titles

The officers of this Corporation shall consist of a President, Vice President, Treasurer, Secretary, and other such officers as the Board may appoint.

Section 2. Nomination and Election

All officers of the corporation shall be selected from the Board of Directors and must be members of the Board of Directors and may be nominated by any member of the Board of Directors.

Section 3. Terms

Officers shall serve for a term of one year or until their successors are duly elected. Officers may be elected for office for up to three consecutive terms. Terms of office begin immediately upon election. Officers may serve more than three terms if a replacing Officer is not duly elected. Officers may be elected to additional nonconsecutive terms.

Section 4. Vacancy

A vacancy in any office shall be filled by the Board of Directors not later than the first regular meeting of the Board of Directors following the meeting at which the vacancy was reported.

Section 5. Other Officers

The Board of Directors may elect or appoint such other officers and agents as it shall deem necessary or desirable. They shall hold their offices for such terms and shall have such authority and perform such duties as shall be determined by the Board of Directors.

Section 6. Removal

Any person elected or appointed by the Board may be removed from office by a vote of a majority of the Board members then serving on the Board. Removal as an officer shall not necessarily mean removal as a Board member.

Section 7. President

The President of the Board of Directors shall oversee the governance of the corporation; shall preside at all meetings of the Board of Directors and Executive Committee; and shall see that all orders and resolutions of the Board of Directors are carried into effect. The President shall have any other powers and duties as may be prescribed from time to time by the Board of Directors. The President is an ex-officio member of all committees.

Section 8. Vice- President

In the absence of the President or in the event of their inability or refusal to act, the Vice-President shall perform the duties of the President, and when so acting, shall have all the powers of the President. The Vice-President shall perform such other duties as from time to time may be assigned by the President or by the Board of Directors.

Section 9. Secretary

The Secretary of the Board of Directors shall have overall responsibility for all record keeping of the Board. Under the direction and supervision of the President of the Board of Directors, the Secretary shall perform, or cause to be performed, the following duties: (a) official recording of the minutes of all proceedings of regular and special meetings of the Members of this Corporation; (b) official recording of the minutes of all proceedings of the Board of Directors meetings and actions; (c) official recording of the minutes of all proceedings of the Executive Committee meetings and actions; (d) provision for notice of all regular and special meetings of Members of this Corporation and of regular and special meetings of the Board of Directors; (e) review revisions to the Articles of Incorporation as needed; (f) preside at meetings of the Board of Directors in the absence of the President and Vice-President; (g) retain the Board Policy Manual and ensure that it is up to date; and (h) any other duties as may be prescribed by the Board of Directors.

Section 10. Treasurer

The Treasurer of the Board of Directors shall have overall responsibility for all corporate funds. The Treasurer shall perform, or cause to be performed, the following duties: (a) keeping of full and accurate accounts of all the financial records of the corporation; (b) the deposit of all monies and other valuable effects in the name and to the credit of the corporation in such depositories as may be designated by the Board of Directors; (c) the disbursement of all funds when proper to do so; (d) making financial reports as to the financial condition of the corporation to the Board of Directors; and (e) any other duties as may be prescribed by the Board of Directors.

Article VII. Executive Director

The Executive Director shall be the chief executive officer of the Corporation and, subject to the direction of the Board of Directors, shall be responsible for the general operation of the Corporation. The Executive Director shall not be a member of the Board of Directors and shall have no vote.

Article VIII. Non-Discrimination Policy

It shall be the operational policy of this Corporation not to discriminate against any person on the basis of race, color, religion (creed), gender, gender expression, age, national origin (ancestry) disability, marital status, sexual orientation, or military status or any other legally protected status in any of its activities or operations. This policy includes, but is not exclusive of, hiring, firing, layoffs, promotions, wages, training, disciplinary action or any other terms, privileges, conditions, or benefits or employment. The aforementioned policy will be applied to any services offered by this Corporation as well. The Corporation is committed to providing an inclusive and welcoming environment for all members of its staff, clients, members, volunteers, contractors, and vendors.

Article IX. Corporate Indemnity

This Corporation will indemnify to the fullest extent not prohibited by law any person who is made or threatened to be made a party to an action, suit, or other proceeding, by reason of the fact that the person is or was a director or officer of this Corporation or a fiduciary within the meaning of the Employee Retirement Income Security Act (or its corresponding future provisions) with respect to any employee benefit plan of this Corporation. No amendment to this Article that limits this Corporation’s obligations to indemnify any person shall have any effect on such obligation for any act or omission that occurs prior to the later of the effective date of the amendment or the date notice of the amendment is given to the person. This Corporation shall interpret this indemnification provision to extend to all persons covered by its provisions the most liberal possible indemnification – substantively, procedurally, and otherwise.

Article X. Amendment of Bylaws

These Bylaws may be amended or repealed, and new Bylaws adopted, by the Board of Directors by an affirmative vote of two-thirds of directors present, if a quorum is present. Prior to the adoption of the amendment, each Director shall be given at least ten days’ notice of the date, time, and place of the meeting at which the proposed amendment is to be considered, and the notice shall state that one of the purposes of the meeting is to consider a proposed amendment to the Bylaws and shall contain a copy of the proposed amendment.

ORIGINAL BYLAWS ADOPTED BY THE BOARD: _____ -